

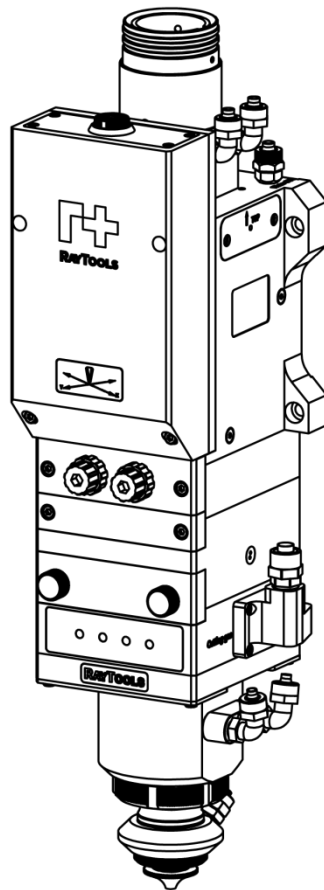

## BS20K SERIES

---

20kW All-In-One Smart Laser Cutting Head - User Manual



**Document History**

<b>Edit date</b>	<b>Version</b>	<b>Topic, revision, action taken</b>
2023/5/22	V1.0	First edition
2023/6/28	V2.0	Configuration update
2023/11/28	V3.0	<ol style="list-style-type: none"><li>1. Alarm info modification</li><li>2. Add requirements of antifreeze and water</li><li>3. Add common consumables.</li></ol>
2024/12/4	V4.0	Add configuration 100:220

Thank you for choosing our product!

This manual describes the installation and commissioning of laser cutting head in details so that you can use this product quickly. You can consult us directly for more details.

Due to the continuous updating of product functions, the product you receive may differ from the introduction in this manual in some aspects.

We reserve all rights in this document including the issued patents and other registered commercial ownership related to this document. It is strictly prohibited to use this document in an improper way especially to copy and disseminate it to third parties.

If you find any errors in this document, please inform us as soon as possible. The data contained in this manual is only used to describe the product and shall not be regarded as a statement of security interest.

For the benefit of our customers, we will constantly try to ensure that the products we develop comply with the latest technology.

**Raytools AG**

Email: [sales@raytools.com](mailto:sales@raytools.com)

Website: [www.raytools.ch](http://www.raytools.ch)

### **Disclaimer**

- We reserve the right to change the design in order to improve the quality or expand the application or comply to manufacturing workmanship.
- We will not bear any responsibility for losses and accidents caused by wrong operation or improper handling of our products.
- Dismantling of product will lose all warranty claims excluding the normal replacement of worn parts and components required for maintenance or commissioning operations.
- Unauthorized modification of products or use of non-original spare parts will directly lead to the invalidation of warranty and liability exemption.
- It is recommended to only use the spare parts provided by us or submit them to us or the designated professional team for installation.

### **Use Regulations**



- Ensure that the product is used in a dry environment.
- Ensure that the product is used in the environment required by EMC standards.
- The product is only allowed to run within the parameters specified in the technical data.

### **Personnel Responsibilities**

- Be familiar with the basic provisions of work safety & accident prevention and have received equipment operation guidance.
- Read and understand basic safety instructions and operations.
- You must have studied the relevant regulations and safety instructions and understand the possible hazards.
- Comply with relevant regulations and implement corresponding protective measures.

## Safety Instructions

### Prevent Electric Shock

-  Parts of the laser head such as nozzle, sensor, sensor interface and attached fasteners may not be fully protected by the ground wire due to function fault. These parts may have low voltage. When installing electrical equipment, please pay attention to taking anti electric shock measures for relevant personnel.
-  Note that the equipment shall be grounded as specified.

### Guard against Danger

- Never put your hands or other body under the laser head.
- Repair and maintenance work can only be carried out after the power is turned off.
- Do not exceed the specified maximum pressure.
- It must be ensured that the laser head is in normal condition at all times.
- All fasteners such as bolts and nuts must be tightened.



### Laser Caution

- Avoid direct laser radiation or scattering to the skin.
- Do not stare at the laser beam even when wearing optical equipment.
- Use special laser protective eyeglasses that meet the requirements of safety standards IEC 60825-1.

### Prevent Waterway Corrosion

- In order to avoid corrosion, use the specified coolant and comply with relevant requirements and specified maintenance intervals.

### Noise Prevention

- The corresponding measures shall be specified or explained and observed in order to prevent personnel from being harmed by noise when the cutting air pressure is high.

### Storage and Transportation

- Observe the storage temperature range allowed by the technical data.
- Take reasonable measures to prevent fire, vibration or impact.
- Do not store in or near the magnetic field.

## Contents

1	Product Summary .....	1
1.1	Structure (with QBH Interface).....	1
1.2	Function.....	2
1.3	Technical Datasheet.....	4
1.4	Mechanical Size .....	5
1.5	Physical Interface.....	7
2	Mechanical Installation .....	8
2.1	Fiber Insertion .....	8
2.2	Mounting of Laser Cutting Head .....	10
2.3	Earthing of Laser Cutting Head.....	11
2.4	Inspection of Top 1 Cover Glass (1 <sup>st</sup> Installation/Replacement of Fiber) .....	12
2.5	Connection of Cooling Water and Assist Gas .....	13
3	System Installation and Commissioning .....	15
3.1	Auto Focus by 0-10V Analog.....	15
3.2	Auto Focus by EtherCAT.....	20
3.3	Mobile APP .....	21
4	Beam Alignment and Zero Focus Correction .....	24
4.1	Beam Alignment .....	24
4.2	Focus Position Setting.....	25
5	Maintenance .....	26
5.1	Cleaning Lens.....	26
5.2	Removal and Installation of Lenses .....	27
5.3	Replace Ceramic Body and Nozzle.....	29

## 1 Product Summary

### 1.1 Structure (with QBH Interface)

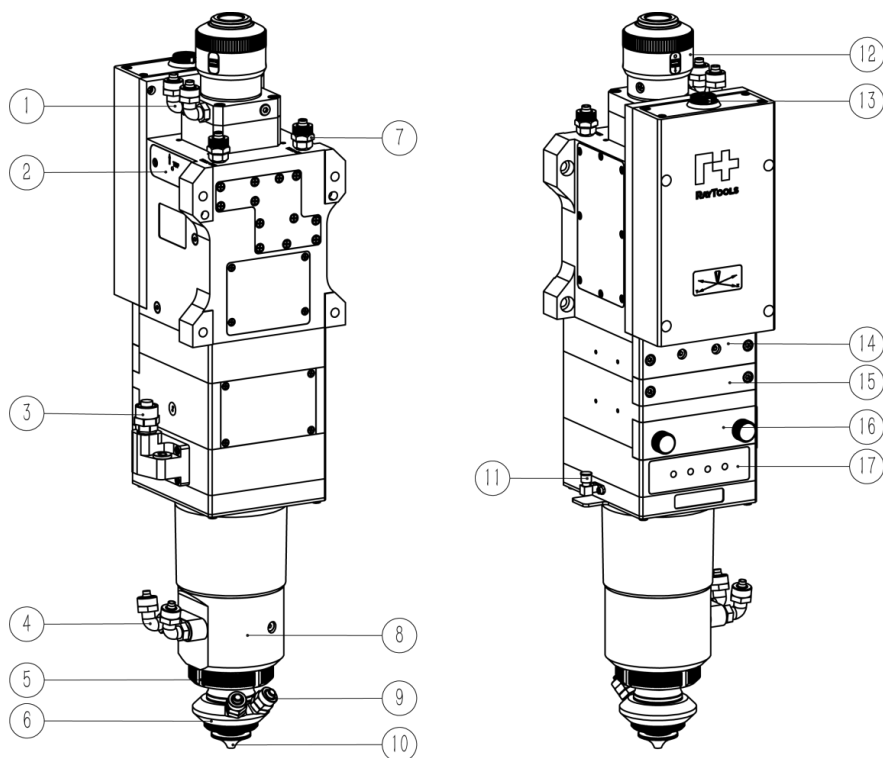

1 Water Cooling Interface (□8)

2 Dual Top Cover Glass

3 Cutting Gas Interface (□12)

4 Water Cooling Interface (□8)

5 Retaining Ring

6 Water Cooling Module

7 Water Cooling Interface (□8)

8 TRA (Nozzle Assy)

9 Water Cooling Interface (□8)

10 Nozzle

11 Pre-amplifier Interface (SMA)

12 Fiber Interface

13 Control Interface

14 Focus Module/XY Alignment

15 Bottom 2 Cover Glass Assy

16 Bottom 1 Cover Glass Assy

17 LED

## 1.2 Function

### 1.2.1 Protection and Monitoring

- Cutting gas pressure detection
- Ready detection of bottom 1 cover glass
- Temperature detection of top 1/ bottom 1 cover glass
- Cavity gas pressure detection
- Cavity temperature detection
- Dual top cover glass

### 1.2.2 Smart Monitoring

- Compatible with PC
- Compatible with Android

### 1.2.3 LED

LED Status Definition (from left to right):

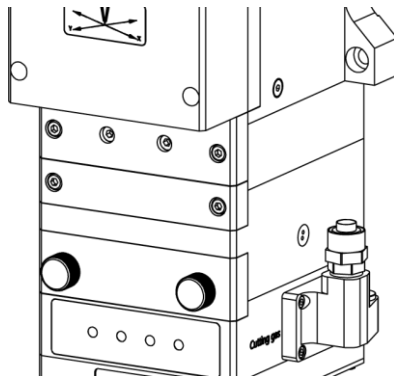

LED No.	LED Status	Status Definition
LED 1	 Light off	Focus not homed or homing failed
	 Green on	Running normally
	 Green blinks	Focus motor homing
	 Red on	Cavity fault
LED 2	 Light off	Dew point alarm (closable)
	 Green on	Running normally
	 Red on	Abnormal temperature of top cover glass/ temperature rise alarm
	 Red blinks	Abnormal temperature of top cover glass/ temperature rise precaution
LED 3	 Light off	Cavity pressure alarm
	 Green on	Running normally
	 Red on	Abnormal temperature of focus lens/ temperature rise alarm
	 Red blinks	Abnormal temperature of focus lens / temperature rise precaution
LED 4	 Light off	Bottom cover glass not ready for operation
	 Green on	Running normally
	 Red on	Abnormal temperature of bottom cover glass/ temperature rise alarm
	 Red blinks	Abnormal temperature of bottom cover glass/ temperature rise precaution

Remark: 4-green LED and 4-red LED will blink alternately while online upgrading.

## 1.3 Technical Datasheet

Model	BS20K
Wavelength	1080nm
Fiber Interface	QD/Q+/QBH/LOE
Power Rating	20kW
Collimation Length (fC)	100mm
Focusing Length (fF)	220/300mm
NA max	0.14
Auto Focus Range(vertically)	-72mm...+72mm (FL300mm) -40mm...+40mm (FL220mm)
Auto Focus Range (horizontally)	-1.5mm...+1.5mm
Mounting Size of Cutting Head	4xM6
Mounting Size of Preampfier	4xM3
Cutting Gas	ø12, max. 25bar
Water Cooling	ø8, max. 5bar, min. 1.5L/min
Operating Voltage	24V±10%, max. 4A
I/O Interface (19-Pin)	Output current must be less than 30mA
Operating Temperature	5°C~55°C
Humidity	30%~95%, without condensing
Weight	8.3kg~8.7kg

## 1.4 Mechanical Size

### Optical Configuration 100:220

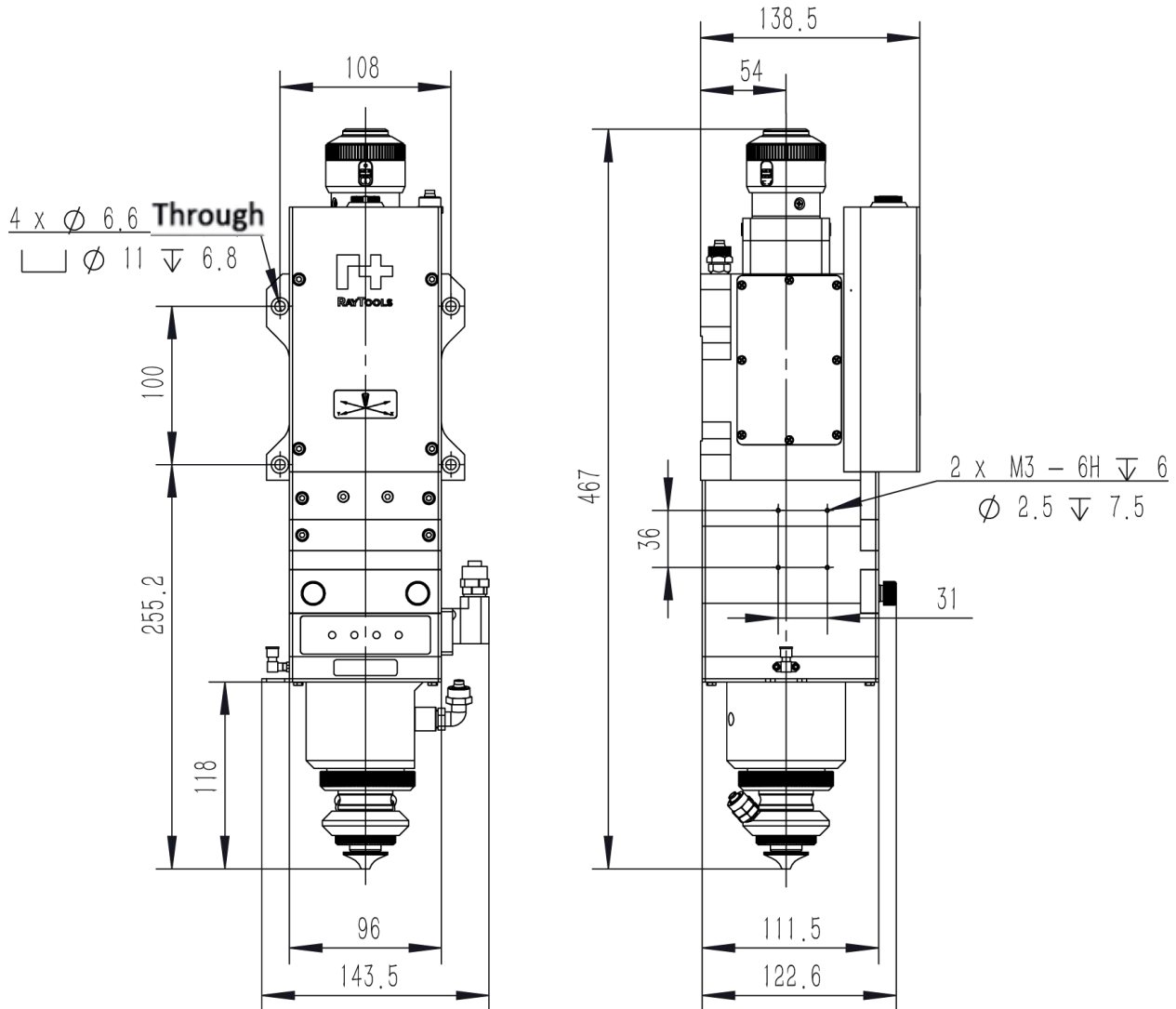

## Optical Configuration 100:300

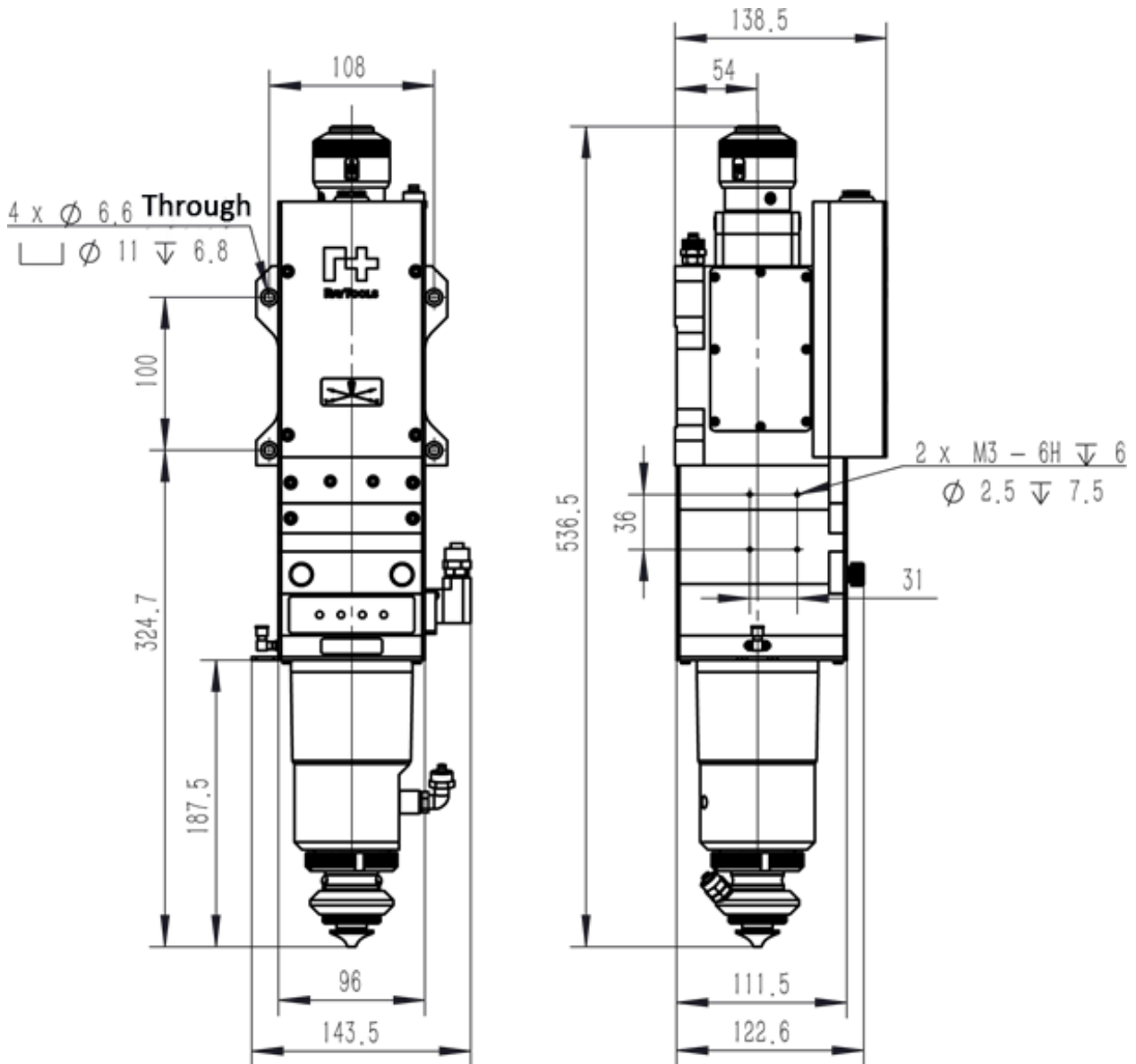

## 1.5 Physical Interface

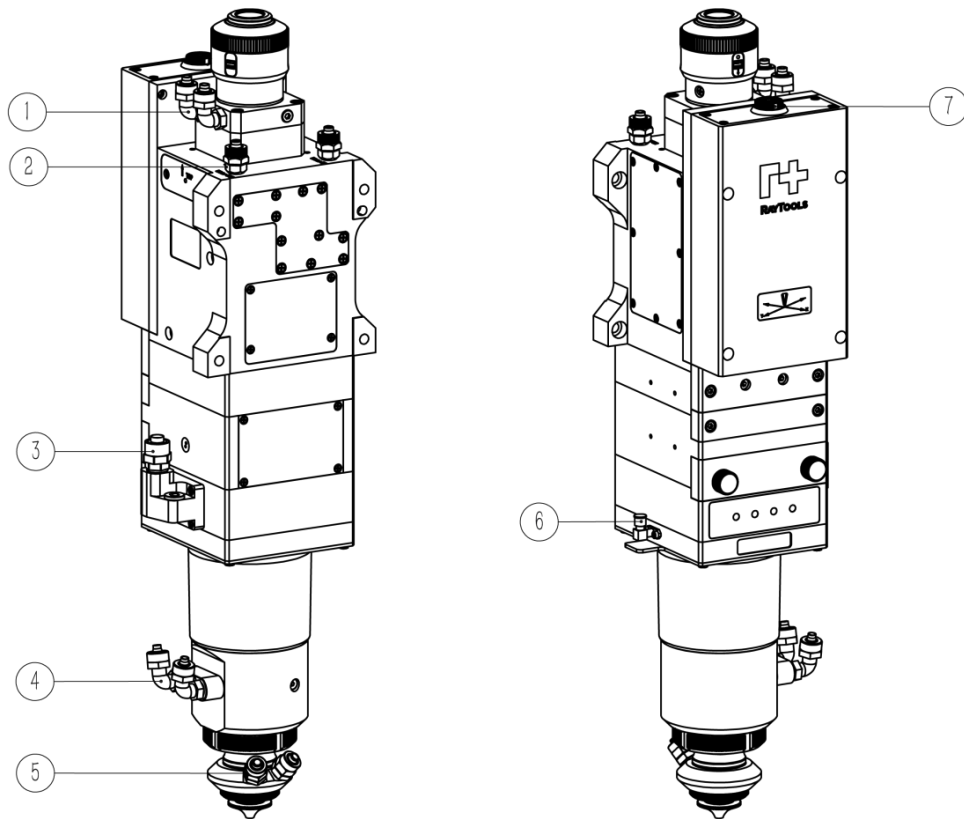

No. 1	Cooling water (ø8)	No. 5	Cooling water (ø8)
No. 2	Cooling water (ø8)	No. 6	Preamplifier (SMA)
No. 3	Cutting gas (ø12)	No. 7	Control interface
No. 4	Cooling water (ø8)		



Note the connection dimensions and the Max. capacity of the interface.

## 2 Mechanical Installation

### 2.1 Fiber Insertion



**WARNING:** The optical components must be dust free and all dusts must be cleaned before use. The fiber shall be horizontally inserted into fiber interface to prevent dust from entering the interface and falling on the lens. Upper limit in the fiber before fixing the laser head.

#### 2.1.1 QBH Fiber Insertion

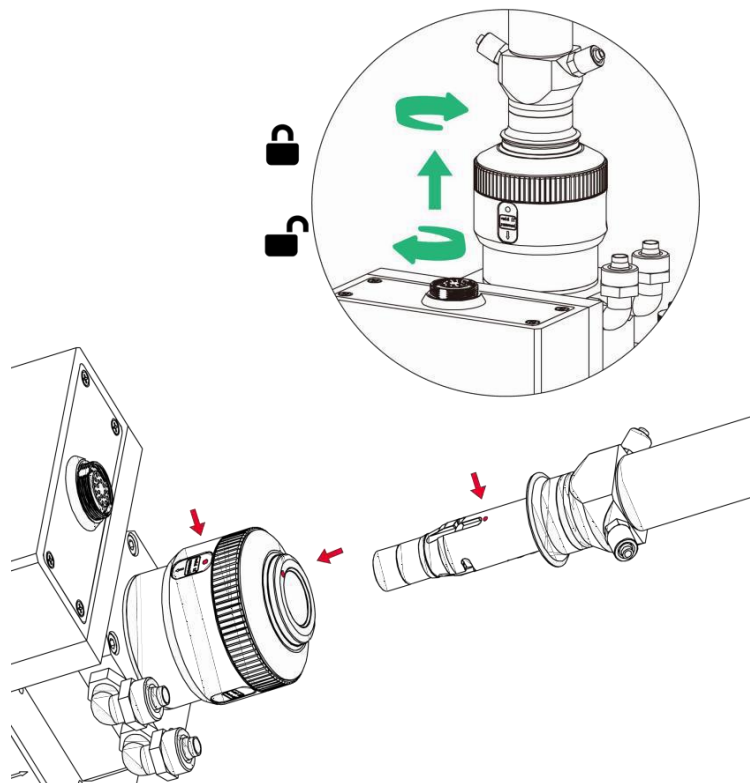

- Place the QBH fiber head and cutting head horizontally.
- Remove the QBH interface dust proof cover
- Align the QBH protrusion to the groove of the cutting head connector, then insert it into the laser head interface
- Press the fiber interface retaining ring, to make the QBH protrusion completely match the groove, then loosen the retaining ring to lock the QBH through natural rebound.

## 2.1.2 LOE Fiber Insertion

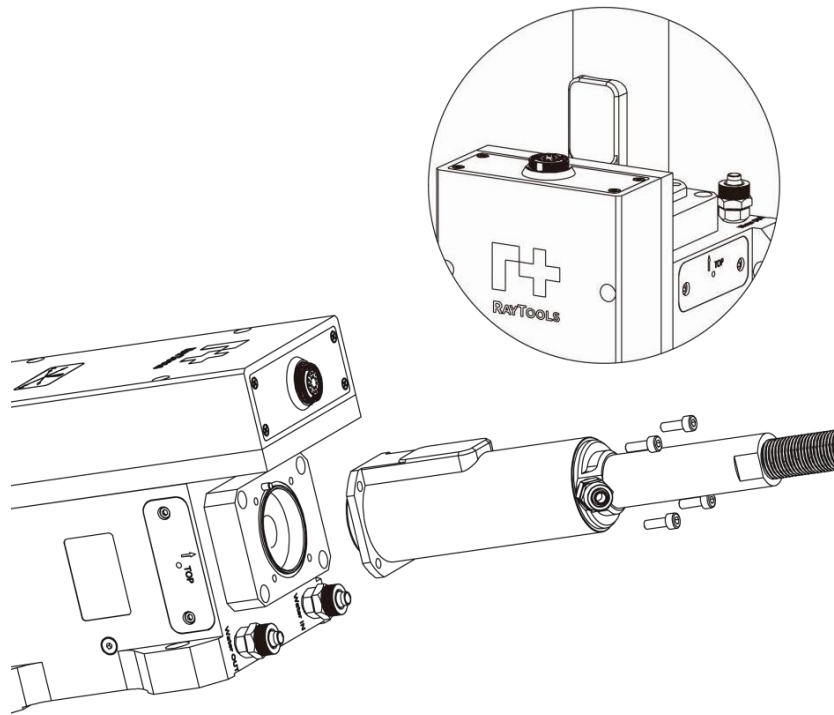

- Remove the dust cover of LOE adaptor.
- Align the locating pin holes of the fiber end and the laser head.
- Lock the fiber end and the laser head with locking screws tightened to the corresponding screw holes.
- Shake the fiber gently after locked, to confirm it is tightened prior to use.

**i** It is recommended to use textured tape to seal the connection of female and male fiber interface after the installation is finished in order to prevent from dust as much as possible in critical dusty environment.

## 2.2 Mounting of Laser Cutting Head

The mounting of laser cutting head to machine tool is shown as below. Customers are advised to Install the laser head perpendicular to the bed surface as requested and make sure the laser head is locked, which is one of the premises to ensure the stable cutting.

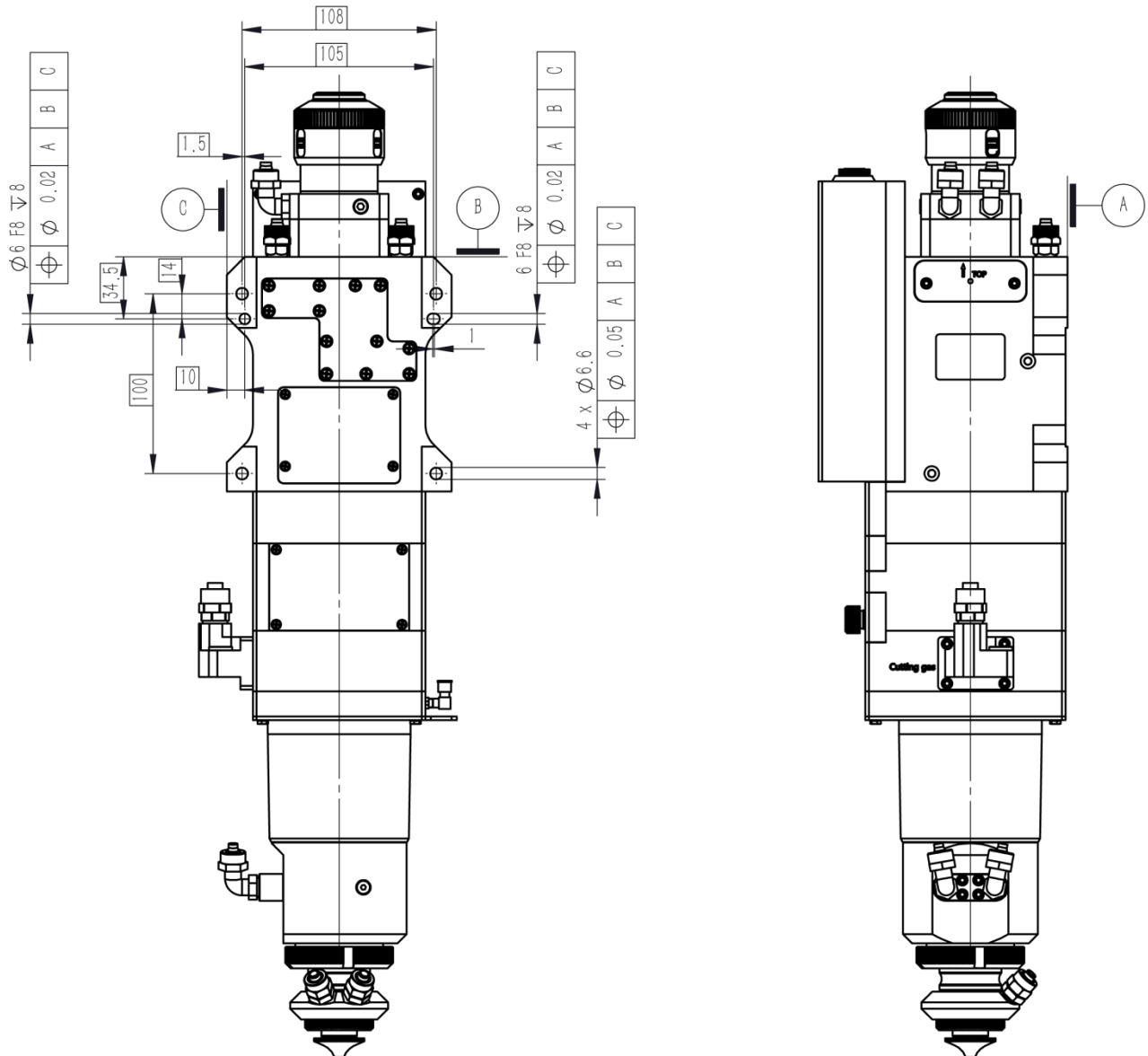

## 2.3 Earthing of Laser Cutting Head

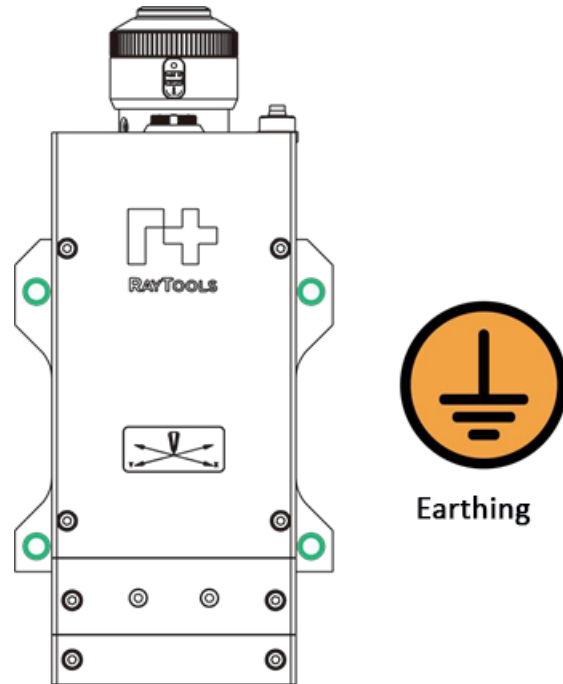

The shaking or vibration of cutting head due to incorrect earthing could cause damage to sensor mechanism and machine.

## 2.4 Inspection of Top 1 Cover Glass (1<sup>st</sup> Installation/Replacement of Fiber)

Maintenance or repair shall be implemented at dust free workstation.

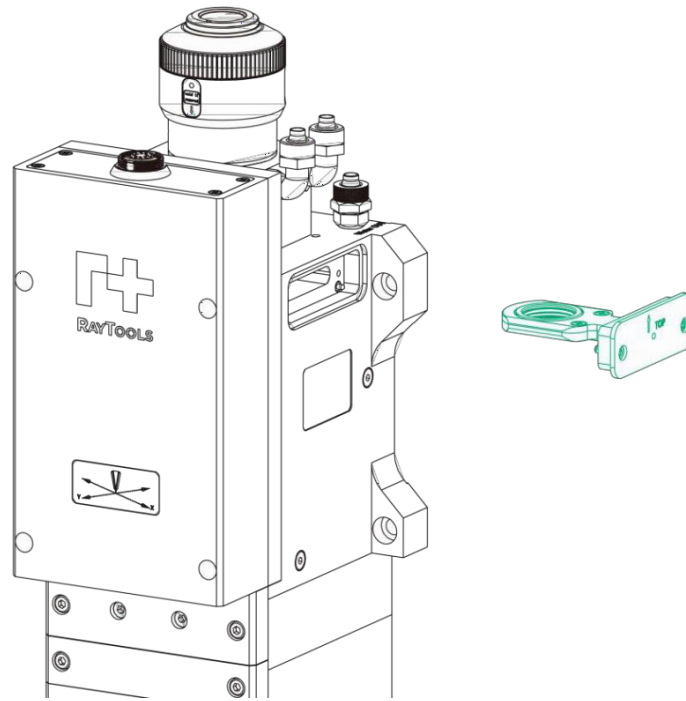

- Loosen bolts and pull out the glass holder until you see the complete cover glass.
- Seal the openings of cutting head by textured tape immediately.
- Check if the top cover glass is clean. If not, blow the cover glass by clean compressed air until it is clean.



The cover glass shall be replaced if it cannot be cleaned or a damage happens.

## 2.5 Connection of Cooling Water and Assist Gas

### 2.5.1 Connection of Cutting Gas

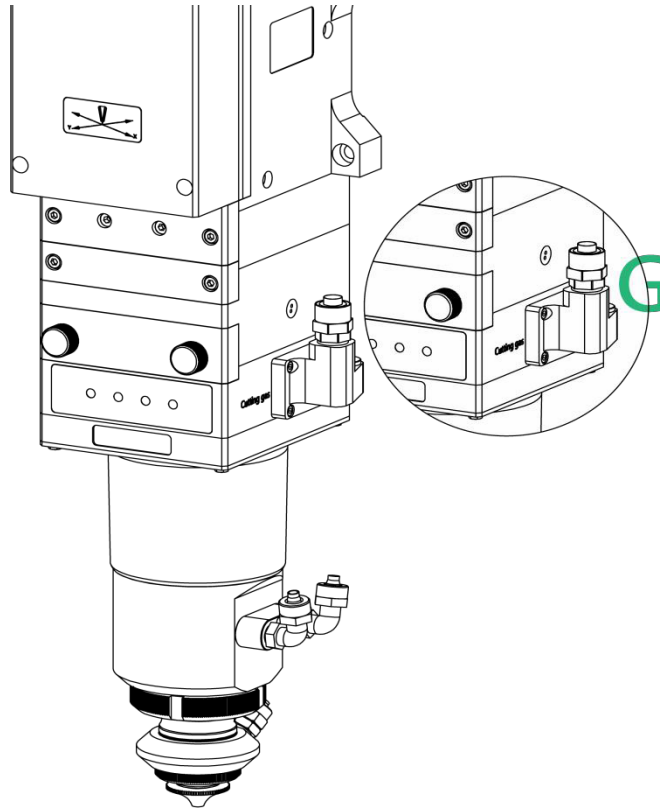

The impurity in cutting gas such as hydrocarbon and steam will damage the lens and cause cutting power fluctuation as well as inconsistencies between the sections of the work piece. The table below is the recommended cutting gas specification. The higher the purity of the gas, the better the quality of the cutting section.

Gas	Purity	Maximum content of water vapor	Maximum content of hydrocarbon
Oxygen	>99.5%	<5 ppm	<1 ppm
Nitrogen	>99.95%	<5 ppm	<1 ppm
Diameter of cutting gas pipe (Outer diameter)		ø12mm (G)	
Gas Pressure		Max. 25bar (2.5MPa)	



**CAUTION:** Gas interface cannot be replaced arbitrarily especially do not use PTFE TAPE. Otherwise the gas path will be blocked and cannot do normal cutting which will damage cutting head at the same time.

## 2.5.2 Connection of Cooling Water

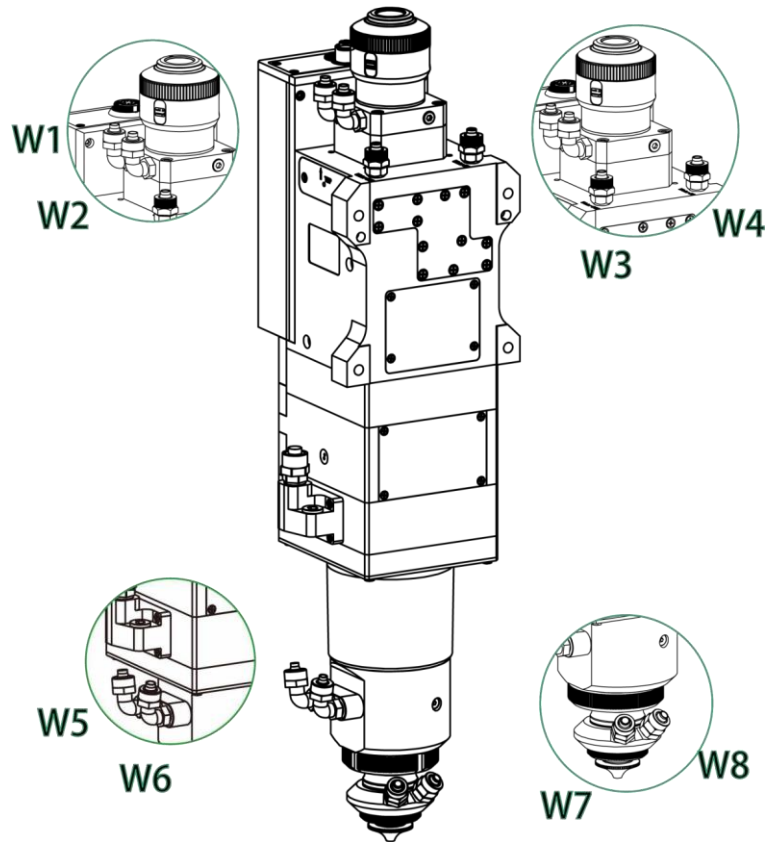

To avoid affecting follow capacitance, it's recommended to select blade battery antifreeze with conductivity less than 3us/cm. The recommended water flow is suggested below.

- Cooling pipe of fiber interface: W1, W2
- Cooling pipe of collimation module: W3, W4,
- Cooling pipe of TRA assy: W5,W6,W7,W8.

**The cooling water must comply with the technical standards in the table below.**

Outer diameter of water hose	ø8mm
Minimum flow speed	1.5 l/min
Entry pressure	170-520kPa
Entry temperature	≥room temperature / > dew point
Hardness (relative to CaCO3)	<200mg/liter
PH range	6 to 8
Particle size allowed	Diameter less than 200 microns
Conductivity	≤10us/cm

## 3 System Installation and Commissioning

### 3.1 Auto Focus by 0-10V Analog

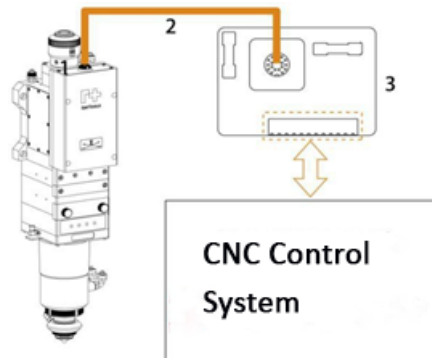

- Connect (1) the 19-pin interface of laser head with (3) I/O-CAN board by (2) the control cable
- Connect all necessary I/O interfaces with CNC
- Connect 24V power supply to the I/O-CAN board
- Complete configuration and commissioning according to the system instruction. With *Raytools* motion control system, user can select to use the default parameter.

I/O-CAN Board

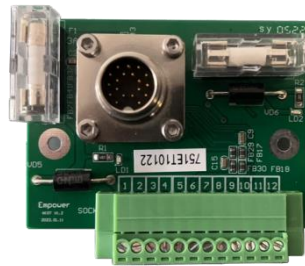

## I/O-CAN Definition

Pin No.	Item	Definition
1	Power supply 24V	24V to power supply
2	Power supply 0V	0V to power supply
3	I/O 24V	24V to I/O
4	I/O 0V	0V to I/O
5	RS485+	485 Communication
6	RS485-	485 Communication
7	Input-Home	24V (Uperedge): Manual homing enable (Keep PNP while homing to prevent being failed) Else: Home disable
8	Input-Focus	24V (Uperedge): Focus enable Else: Focus disable
9	Output-Alarm	Floating (High Impedance State): Alarm 0V: no alarm
10	Output-Focus reached	0V: Focus reached Floating (High Impedance State): Focus unreached
11	Input-Analog +	0.3V-9.7V Auto focus
12	Input-Analog -	

**Remark:** connect Pin 11, Pin 12 by the complimentary shielded twisted pair.

Take the connection to *FSCUT* system as an example:

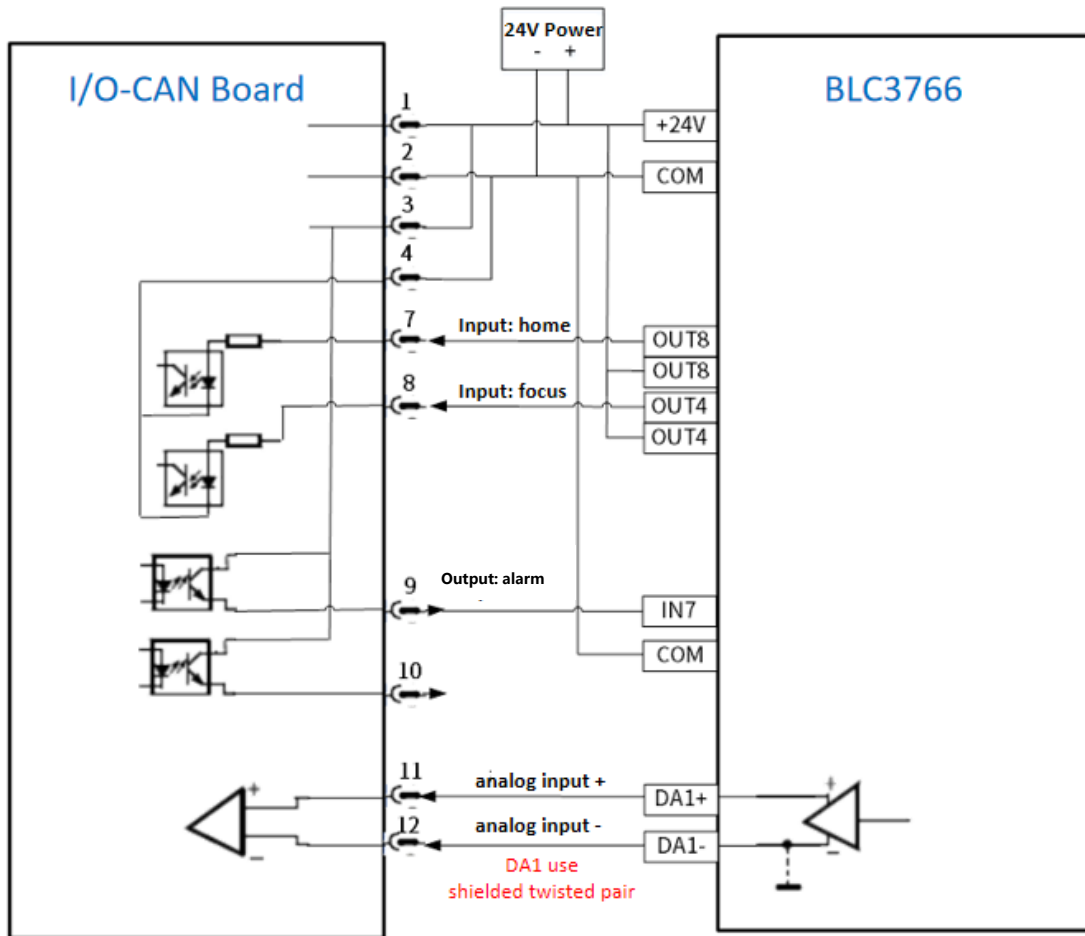

Wiring diagram

After the wiring is completed, enter the system setting. The following parameters are only for

reference. Optical Configuration 100:220

### Laser head

Brand: Raytools

Model: BS20K

Focus control mode: 0-10V Analog output

Height sensor type: EDS On Board

Height sensor signal port: Slave ID4:Height Sensor Capaci

Focus adjrmt

**Laser Head Parameter**

Voltage range (V): 0.3 ~ 9.7

Focal range (mm): 40 ~ -40

Voltage of zero focus: 5 v

Focusing enable delay: 300 ms

Return to origin delay: 10000 ms

Focus analog output: Slave ID4: AO\_1

Focus enable: Slave ID4: DO\_3

Return to origin: Slave ID4: DO\_5

Cutting head alarm: Slave ID4: DI\_16

Shield cutting head alarm

Curve of voltage focus point

FSCUT system setting:

### Focus Control

Enable

The fourth 
  Precitec 
  HighYAG 
  Procutter-Zoom 
  Ecot Ext Board[No Co:

Range: From -40mm to 40mm

Focus voltage (DA): DA2 **Analog**

DA voltage range: From 9.7V to 0.3V

Cut-off voltage: 0.3V

DA delay: 20ms

Confirm focus (out): 4 **Enable focus**

Confirm delay: 300ms

Feedback voltage (AD): No Use  Enable temp. compensation

Function selection (ou): 0

Return Origin(out): 8 **Home**

Return Origin delay: 10000ms

Focus z-direction

## Optical Configuration 100:300

Raytools system setting:

**Laser head**

Brand: Raytools

Model: BS12K/20K/25K/30K/35K 100:300

Height sensor signal port: Node 4:Height Sensor Capacitance

Focus control port/servo: Node 4:Focus Axis (EDS Onboard)

Use Other Driver

Focus adjmt

**Laser Head Parameter**

Voltage range (V): 0 ~ 10

Focal range (mm): 72 ~ -72

Voltage of zero focus: 5 v  Manual inp...

Focusing enable delay: 300 ms

Return to origin delay: 10000 ms

Focusing voltage stabilizat...: 20 ms

Focus analog output p...: Node 4:AO\_1

Focus enable: Node 4:DO\_3

Return to origin: Node 4:DO\_5

FocusDone: Node 4:DI\_14

Cutting head alarm: Node 4:DI\_16

Shield cutting he...

Curve of voltage focus point

Voltage V	Focus mm
0	72
5	0
10	-72

FSCUT system setting:

**Focus Control**

Enable

The fourth 
  Precitec 
  HighYAG 
  Procutter-Zoom 
  Ecot Ext Board[No Co

Range: From 72mm to -72mm

Focus voltage(DA): DA1 **Analog**

DA voltage range: From 0.3V to 9.7V

Cut-off voltage: 0.3V

DA Delay: 10ms

Confirm focus(out): 4 **Enable focus**

Confirm delay: 300ms

Feedback voltage(AD): No Use  Enable temp. compensation

Function selection (ou): 0

Return Origin(out): 8 **Home**

Return ORG delay: 10000ms



The connections and settings may differ from one CNC control system to another. Once the setting is modified, the corresponding wiring method may need to be changed.

## 3.2 Auto Focus by EtherCAT

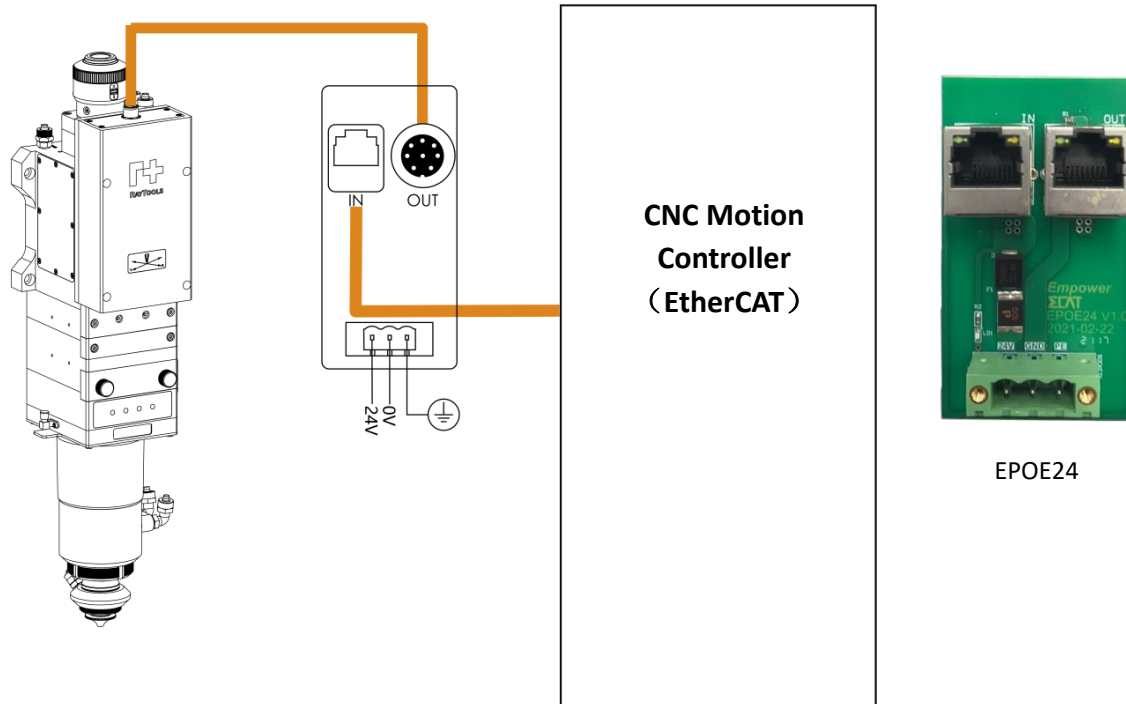

- Connect 24V power supply to the I/O board (EPOE24)
- Connect by network cable as shown above
- Complete configuration and commissioning according to the system instruction

### EPOE24 Definition

No.	Definition	Remark
IN	Input-Interface	Signal input
OUT	Output-Interface	Signal output
24V	Power supply 24V	24V to power supply
GND	Power supply 0V	0V to power supply
PE	Earthing	For earthing

### 3.3 Mobile APP

- Start the software and operate connection according to the instruction.
- Set value based on actual needs.

Examples as below:

Item	Remark	Set Value
Zero Focus Offset	To correct according to actual zero focus position	
Alarm Temp-Top Cover Glass	Alarm threshold 45°C	45°C
Alarm Temp-Bottom Cover Glass	Alarm threshold 45°C	45°C
Alarm Temp- Focus Lens	Alarm threshold 45°C	45°C
Alarm Temp- Cavity	Alarm threshold 45°C	45°C
Alarm Pressure-Cavity	Alarm threshold 1.5 bar	1.5 bar

PC monitoring can display the data after connecting its USB or wifi to the hotspot of the cutting head.

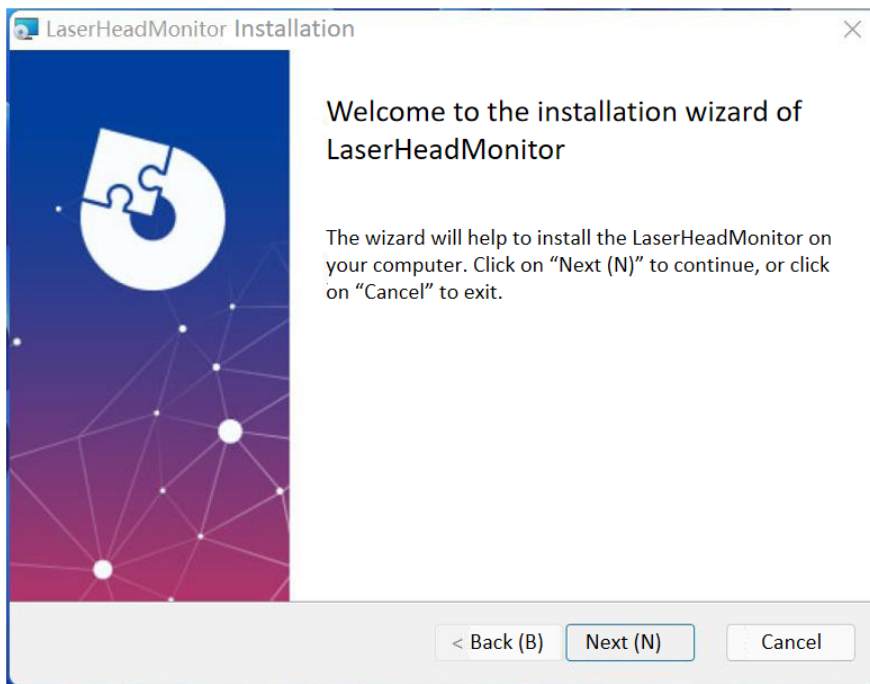

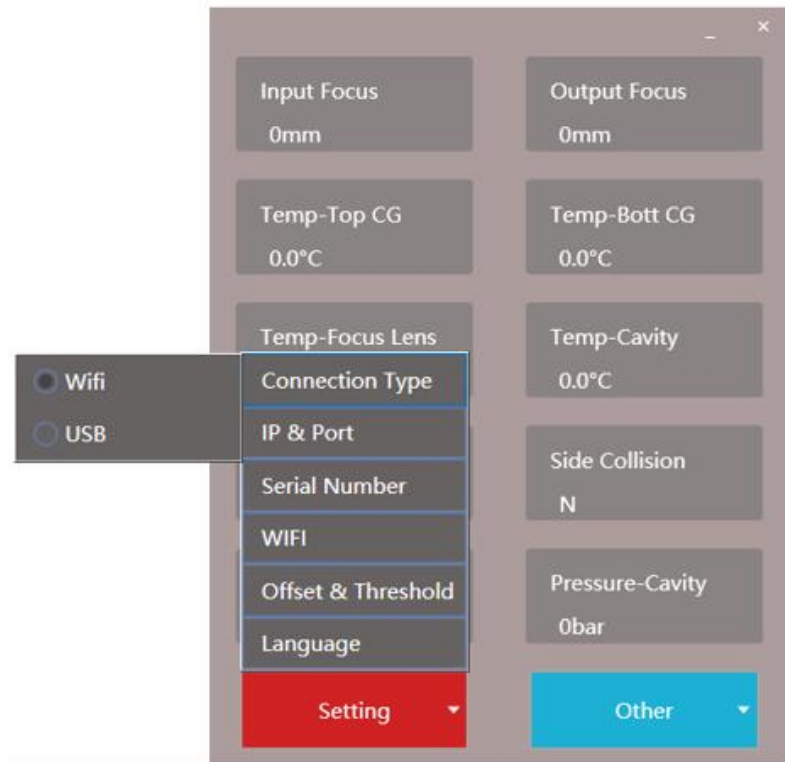

Open the monitoring software and there will be a hover ball on top of the display, double click the hover ball to display detailed information.

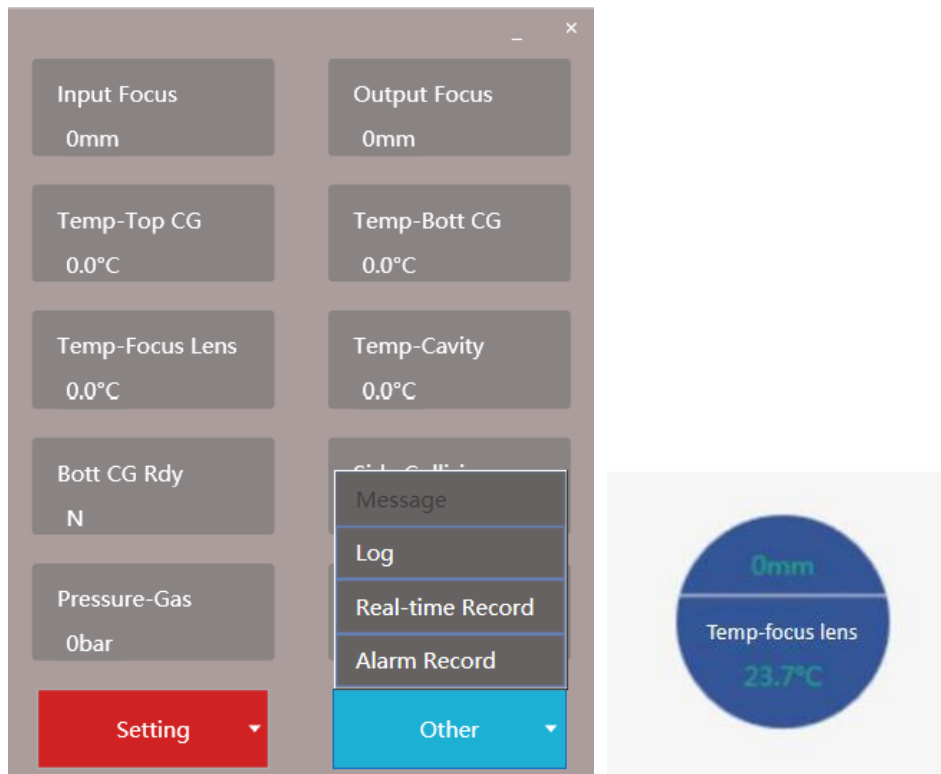

Real-time sensor data can be monitored manually. If an alarm occurs in the cutting head, history data for 1 minute prior to the alarm is auto-recorded.

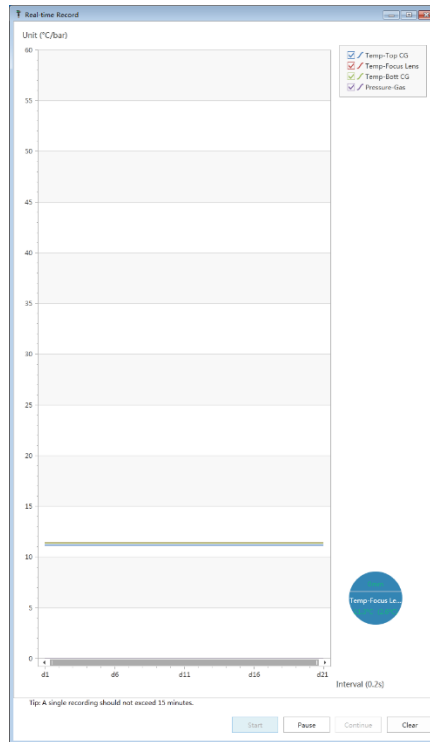

Note: The RS-485 to USB cable will be attached with the head to connect with HMI PC.

## 4 Beam Alignment and Zero Focus Correction

### 4.1 Beam Alignment

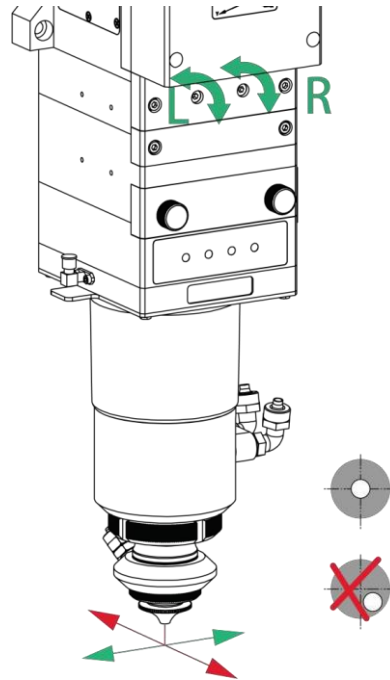

Cutting quality in a great extent depends on whether the lens is in the middle. If the lens is not in the middle, the laser beam may contact with nozzle or inner wall to produce high temperature deformation. Lens alignment operation should be considered when nozzle is replaced or the cutting quality declines.

Lens alignment of laser cutting head can be finished by adjusting focus lens, X-Y direction. The X/Y adjusting knob is located above bottom cover glass as shown below. Adjusting the 2 knobs until the beam is located in the middle of nozzle. Make sure the laser beam output from the center of nozzle. A method commonly used is tape dotting method as below:

- Fix the cutting head with a big size nozzle (tip size shall be larger than beam size) or adjust to nearly zero focus.
- Pick a scotch tape, flatten it and stick it to the nozzle tip.
- Open the red light of the laser. Find and observe the position of red light in the scotch tape.
- Shoot laser at low power to check beam penetration size. Beam penetration shall be circle and located in the nozzle tip center.
- Adjust the 2 X/Y adjusting knobs to get beam aligned. The max X/Y adjusting range is roughly from -1.5mm to +1.5mm.
- Tear off the tape and check the shooting hole position in tape.
- Repeat the above steps to find out relatively centered position.

## 4.2 Focus Position Setting

Focus & Voltage Curve ((Take CL100mm/FL300mm, Mainboard Ver300 as Reference)

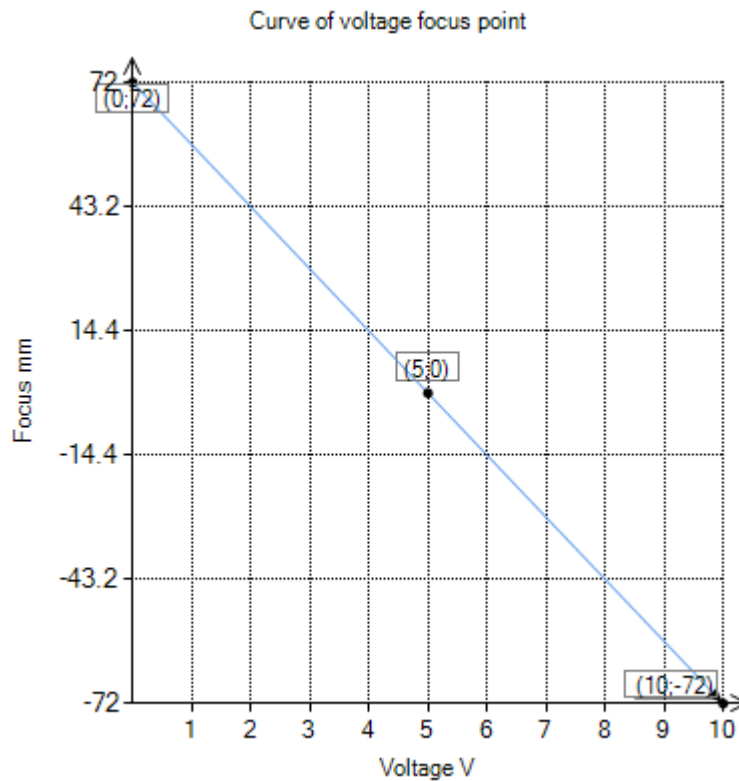

**Note:**

1. CL100mm/FL300mm: 0.3V corresponds to +72mm. 9.7V corresponds to -72mm.
2. Mechanical and optical manufacturing tolerance, matching tolerance between imaging proportion of optical component and optical fiber will have other effects on the actual focus position.
3. Adjust the focus offset according to the actual situation.

## 5 Maintenance

### 5.1 Cleaning Lens

It's necessary to maintain lenses regularly because of the characteristic of laser cutting process. Cleaning to the cover glass once a week is recommended. The collimation lenses and focusing lenses are recommended to be cleaned once every 2~3 months. In order to facilitate the maintenance of the cover glass, the cover glass holder adopts a drawer type structure.

**Tools: Dust-proof gloves or fingertip, polyester swab, absolute ethanol, rubber gas blow (purely compressed air).**

#### **Cleaning instruction:**

- To put fingertip onto left thumb and index finger.
- Spray absolute ethanol onto the polyester swab.
- Hold the edge of the lens with left thumb and index finger gently. (note: avoid touching the surface of the lens by fingertip in case of trace)
- Hold the lens to face eyes by left hand and hold the polyester swab by right hand. Wipe the lens gently in single direction, from bottom to top or from left to right (Should not wipe back and forth in case of secondary pollution to lens) and use rubber blow (purely compressed air) to blow the surface of the lens. Both surfaces should be cleaned. After cleaning, make sure that there is no residual like detergent, floating ash, foreign matters and impurities.

## 5.2 Removal and Installation of Lenses

The whole process needs to be completed in a dust free room. Wear dust-proof gloves or fingertips when removing or installing the lenses.

### 5.2.1 Removal and Installation of Bottom 1 Cover Glass/Protection Glass

The cover glass is wearing part which needs to be replaced once it is damaged.

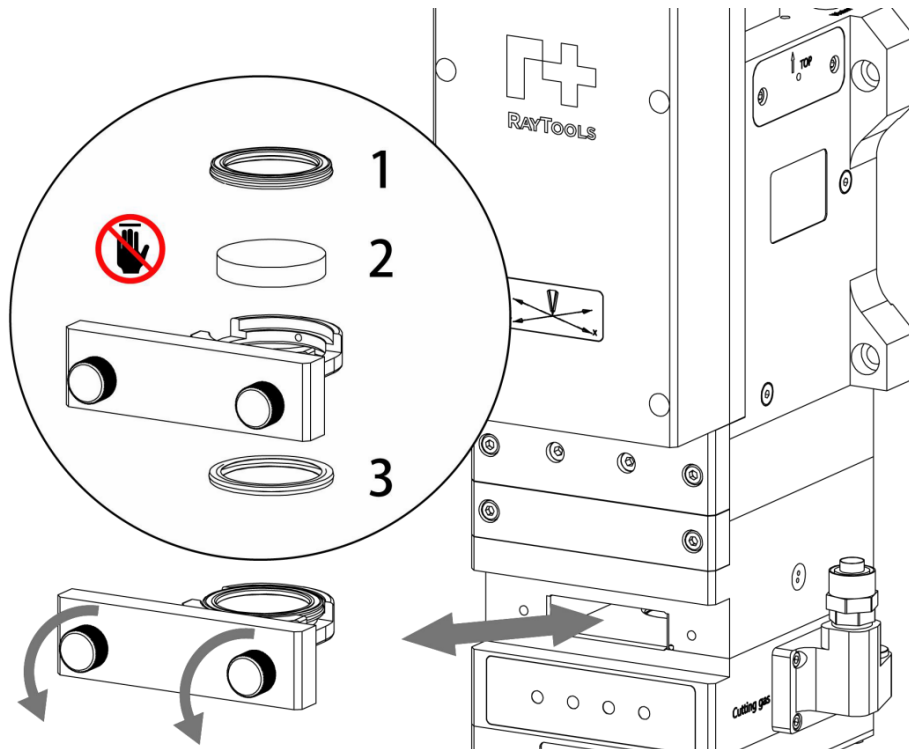

- As shown above, loosen the 2 bolts to pull out cover glass holder by pinching 2 edges of drawer type holder.
- Seal the mounting openings by textured tape immediately.
- Remove the pressing ring (1) and cover glass (2) after wearing fingertips
- Clean the cover glass holder and seal ring (3). The elastic seal ring (3) should be replaced if it is damaged.
- Install the cleaned or new cover glass (regardless of the front or back surface) into the holder of cover glass.
- Install the pressing ring.
- Insert the cover glass holder back to the laser head and tighten the bolts.



**It is not allowed to pull out the edge of seal ring directly as it is very easy to damage the seal ring.**

**Please wear the clean gloves or fingertips.**

## 5.2.2 Removal and Installation of Bottom 2 Cover Glass/Protection Glass

The cover glass is wearing part which needs to be replaced once it is damaged.

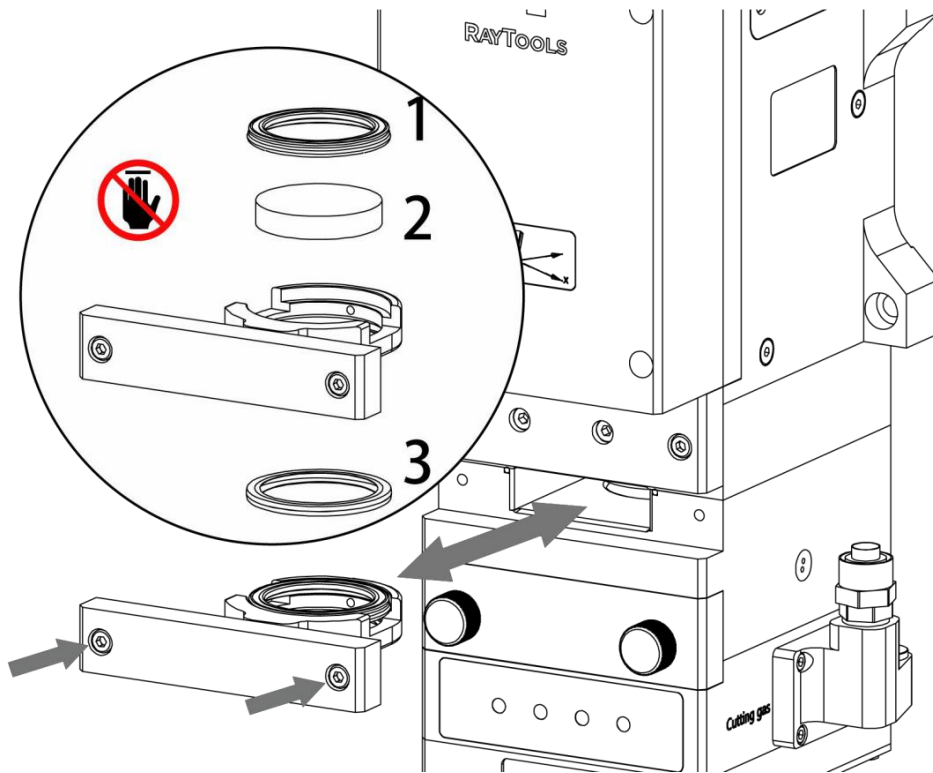

- As shown above, loosen the 2 bolts to pull out cover glass holder by pinching 2 edges of drawer type holder.
- Seal the mounting openings by textured tape immediately.
- Remove the pressing ring (1) and cover glass (2) after wearing fingertips
- Clean the cover glass holder and seal ring (3). The elastic seal ring (3) should be replaced if it is damaged.
- Install the cleaned or new cover glass (regardless of the front or back surface) into the holder of cover glass.
- Install the pressing ring.
- Insert the cover glass holder back to the laser head and tighten the bolts.



**It is not allowed to pull out the edge of seal ring directly as it is very easy to damage the seal ring. Please wear the clean gloves or fingertips.**

## 5.3 Replace Ceramic Body and Nozzle

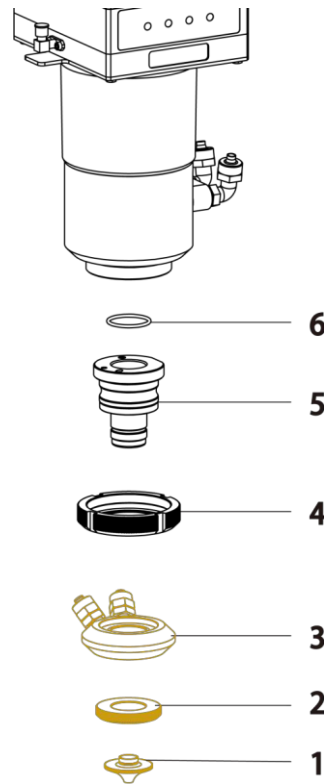

The nozzle is required to be replaced if it gets crash or damaged by laser beam. The dirt on ceramic body is required to be cleaned or to replace the ceramic body if it gets crash.

- Unscrew the nozzle (1) and remove washer (2) and cooling module (3).
- Press the ceramic body (5) upward by hand to make it fixed without deflection and then unscrew the retaining ring (4).
- Align the pin hole of the new ceramic body with the locating pin. Press the ceramic body (5) upward by hand and tighten the retaining ring (4).
- Install the cooling module (3) and washer (2). Screw the nozzle (1) and get it properly tightened.
- Do the capacitance calibration once again after replacing the nozzle or ceramic body.



Only tighten the nozzle and retaining ring by hand (without tools) otherwise it could damage the ceramic body.



Keep the contact surface of all parts clean.