

BS15K SERIES

15kW Auto Focus Smart Laser Cutting Head - User Manual

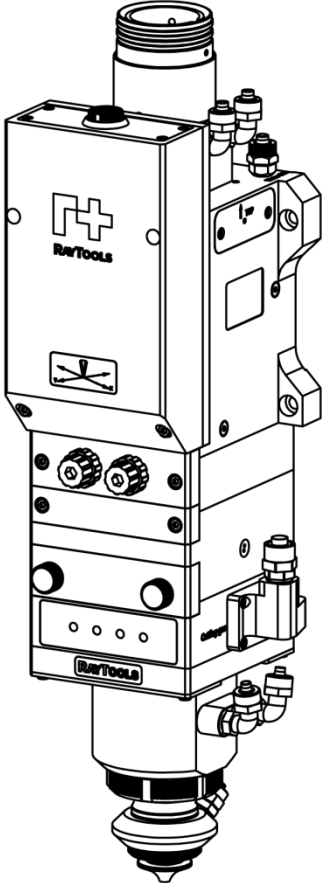

Document History

Edit date	Version	Topic, revision, action taken
2023/5/22	V1.0	First edition
2023/6/28	V2.0	Configuration update
2023/11/27	V3.0	<ol style="list-style-type: none">1. Alarm optimization2. Add common consumables

Thank you for choosing our product!

This manual describes the installation and commissioning of laser cutting head in details so that you can use this product quickly. You can consult us directly for more details.

Due to the continuous updating of product functions, the product you receive may differ from the introduction in this manual in some aspects.

We reserve all rights in this document including the issued patents and other registered commercial ownership related to this document. It is strictly prohibited to use this document in an improper way especially to copy and disseminate it to third parties.

If you find any errors in this document, please inform us as soon as possible. The data contained in this manual is only used to describe the product and shall not be regarded as a statement of security interest.

For the benefit of our customers, we will constantly try to ensure that the products we develop comply with the latest technology.

Raytools AG

Email: sales@raytools.com

Website: www.raytools.ch

Disclaimer

- We reserve the right to change the design in order to improve the quality or expand the application or comply to manufacturing workmanship.
- We will not bear any responsibility for losses and accidents caused by wrong operation or improper handling of our products.
- Dismantling of product will lose all warranty claims excluding the normal replacement of worn parts and components required for maintenance or commissioning operations.
- Unauthorized modification of products or use of non-original spare parts will directly lead to the invalidation of warranty and liability exemption.
- It is recommended to only use the spare parts provided by us or submit them to us or the designated professional team for installation.

Use Regulations



- Ensure that the product is used in a dry environment.
- Ensure that the product is used in the environment required by EMC standards.
- The product is only allowed to run within the parameters specified in the technical data.

Personnel Responsibilities

- Be familiar with the basic provisions of work safety & accident prevention and have received equipment operation guidance.
- Read and understand basic safety instructions and operations.
- You must have studied the relevant regulations and safety instructions and understand the possible hazards.
- Comply with relevant regulations and implement corresponding protective measures.

Safety Instructions

Prevent Electric Shock

-  Parts of the laser head such as nozzle, sensor, sensor interface and attached fasteners may not be fully protected by the ground wire due to function fault. These parts may have low voltage. When installing electrical equipment, please pay attention to taking anti electric shock measures for relevant personnel.
-  Note that the equipment shall be grounded as specified.

Guard against Danger

- Never put your hands or other body under the laser head.
- Repair and maintenance work can only be carried out after the power is turned off.
- Do not exceed the specified maximum pressure.
- It must be ensured that the laser head is in normal condition at all times.
- All fasteners such as bolts and nuts must be tightened.



Laser Caution

- Avoid direct laser radiation or scattering to the skin.
- Do not stare at the laser beam even when wearing optical equipment.
- Use special laser protective eyeglasses that meet the requirements of safety standards IEC 60825-1.

Prevent Waterway Corrosion

- In order to avoid corrosion, use the specified coolant and comply with relevant requirements and specified maintenance intervals.

Noise Prevention

- The corresponding measures shall be specified or explained and observed in order to prevent personnel from being harmed by noise when the cutting air pressure is high.

Storage and Transportation

- Observe the storage temperature range allowed by the technical data.
- Take reasonable measures to prevent fire, vibration or impact.
- Do not store in or near the magnetic field.

Contents

1	Product Summary	1
1.1	Structure	1
1.2	Function	2
1.3	Technical Datasheet	4
1.4	Mechanical Size (Optical Configuration 100:200)	5
1.5	Physical Interface	6
2	Mechanical Installation	7
2.1	Fiber Insertion	7
2.2	Mounting of Laser Cutting Head	9
2.3	Earthing of Laser Cutting Head	10
2.4	Inspection of 1st Top Cover Glass (1 st Installation/Replacement of Fiber)	11
2.5	Connection of Cooling Water and Assist Gas	12
3	System Installation and Commissioning	14
3.1	Auto Focus by 0-10V Analog	14
3.2	Auto Focus by EtherCAT	18
3.3	PC-based Monitoring Software	19
4	Beam Alignment and Zero Focus Correction	22
4.1	Beam Alignment	22
4.2	Focus Position Setting	23
5	Maintenance	24
5.1	Cleaning Lens	24
5.2	Removal and Installation of Lenses	25
5.3	Replace Ceramic Body and Nozzle	30
6	Consumables	31

1 Product Summary

1.1 Structure

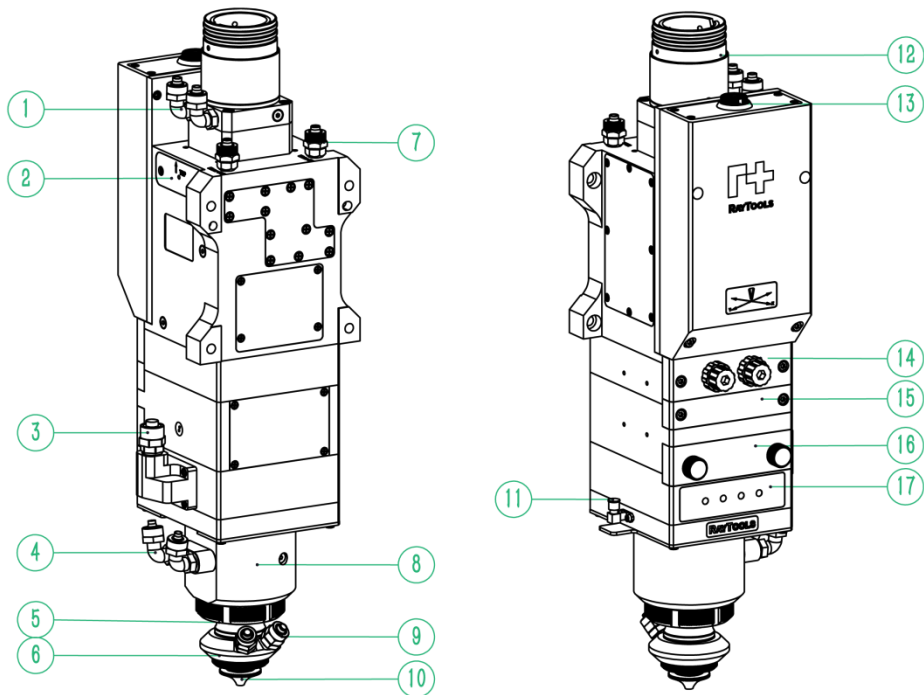

1 Water Cooling Interface (□8)

2 Dual Top Cover Glass

3 Cutting Gas Interface (□12)

4 Water Cooling Interface (□8)

5 Ceramic Ring

6 Water Cooling Module

7 Water Cooling Interface (□8)

8 TRA (Nozzle Assy)

9 Water Cooling Interface (□8)

10 Nozzle

11 Preamplifier Interface

12 Fiber Interface

13 Control Interface

14 Focus Module/XY Alignment

15 Middle Cover Glass Assy

16 Bottom Cover Glass Assy

17 LED

1.2 Function

1.2.1 Protection and Monitoring

- Cutting gas pressure detection
- Bottom cover glass ready detection
- Temperature detection of bottom cover glass
- Temperature detection of top cover glass
- Cavity gas pressure detection
- Cavity temperature detection
- Dual top cover glass

1.2.2 Smart Monitoring

- Compatible with PC
- Compatible with Apple/Android

1.2.3 LED

LED Status Definition (from left to right):

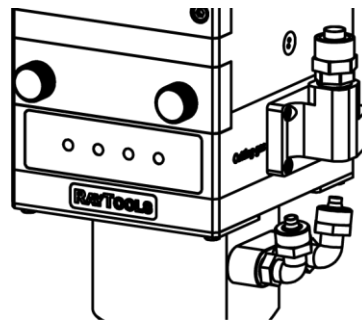

LED No.	LED Status	Status Definition
LED 1	 Light off	Focus not homed or homing failed
	 Green on	Running normally
	 Green blinks	Focus motor homing
	 Red on	Cavity fault
LED 2	 Light off	Dew point alarm (closable)
	 Green on	Running normally
	 Red on	Abnormal temperature of top cover glass/ temperature rise alarm
	 Red blinks	Abnormal temperature of top cover glass/ temperature rise precaution
LED 3	 Light off	Cavity pressure alarm
	 Green on	Running normally
	 Red on	Abnormal temperature of focus lens/ temperature rise alarm
	 Red blinks	Abnormal temperature of focus lens/ temperature rise precaution
LED 4	 Light off	Bottom cover glass not ready for operation
	 Green on	Running normally
	 Red on	Abnormal temperature of bottom cover glass/ temperature rise alarm
	 Red blinks	Abnormal temperature of bottom cover glass/ temperature rise precaution
Remark: 4-green LED and 4-red LED will blink alternately while online upgrading.		

1.3 Technical Datasheet

Model	BS15K
Wavelength	1080nm
Fiber Interface	QD/Q+/QBH/LOE3.1/LOE3.2
Power Rating	15kW
Collimation Length (fC)	100mm
Focusing Length (fF)	200mm
NA max	0.14
Auto Focus Range(vertically)	-40mm...+40mm
Auto Focus Range (horizontally)	-1.5mm...+1.5mm
Mounting Size of Cutting Head	4xM6
Mounting Size of Preampfier	4xM3
Cutting Gas	ø12, max. 25bar
Water Cooling	ø8, max. 5bar, min. 1.5L/min
Operating Voltage	24V±10%, max. 4A
I/O Interface (19-Pin)	Output current must be less than 30mA
Operating Temperature	5°C~55°C
Humidity	30%~95%, without condensing
Weight	8.3kg~8.7kg

1.4 Mechanical Size (Optical Configuration 100:200)

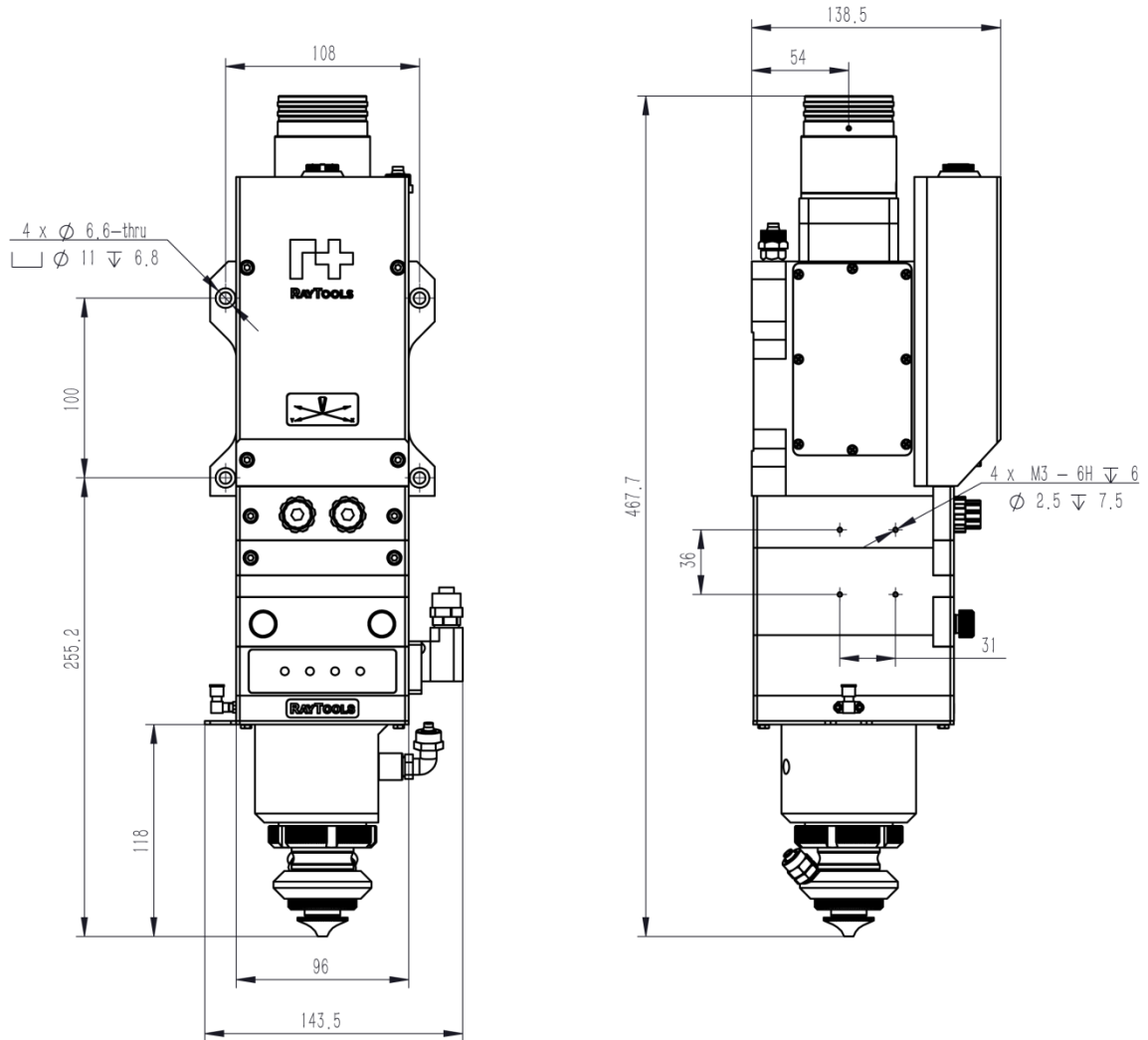

1.5 Physical Interface

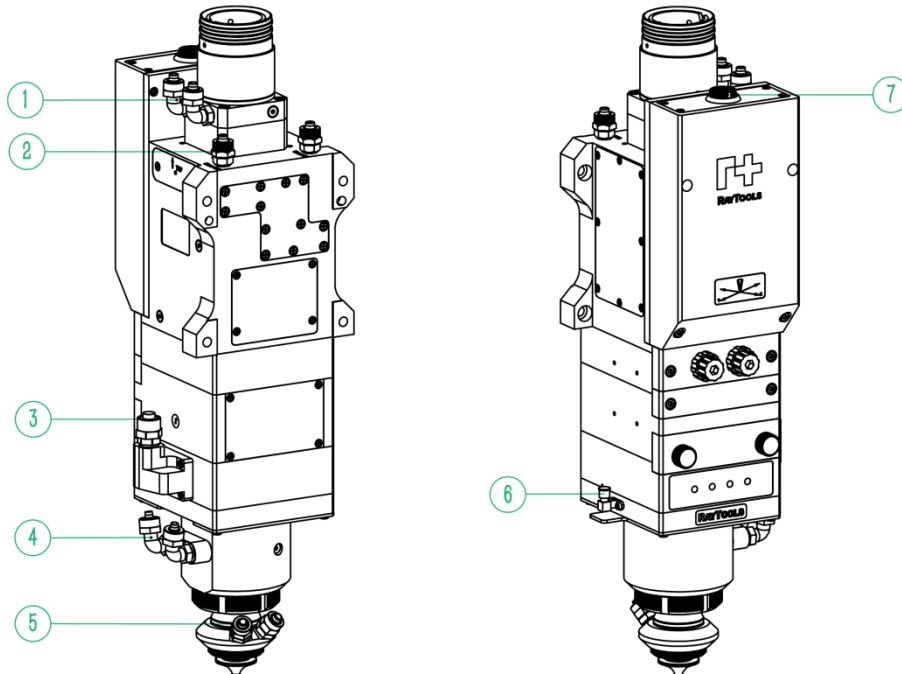

No. 1	Cooling water (ø8)	No. 5	Cooling water (ø8)
No. 2	Cooling water (ø8)	No. 6	Preamplifier (SMA)
No. 3	Cutting gas (ø12)	No. 7	Control interface
No. 4	Cooling water (ø8)		



Note the connection dimensions and the Max. capacity of the interface.

2 Mechanical Installation

2.1 Fiber Insertion



WARNING: The optical components must be dust free and all dusts must be cleaned before use. The fiber shall be horizontally inserted into fiber interface to prevent dust from entering the interface and falling on the lens. Upper limit in the fiber before fixing the laser head.

2.1.1 QD Fiber Insertion

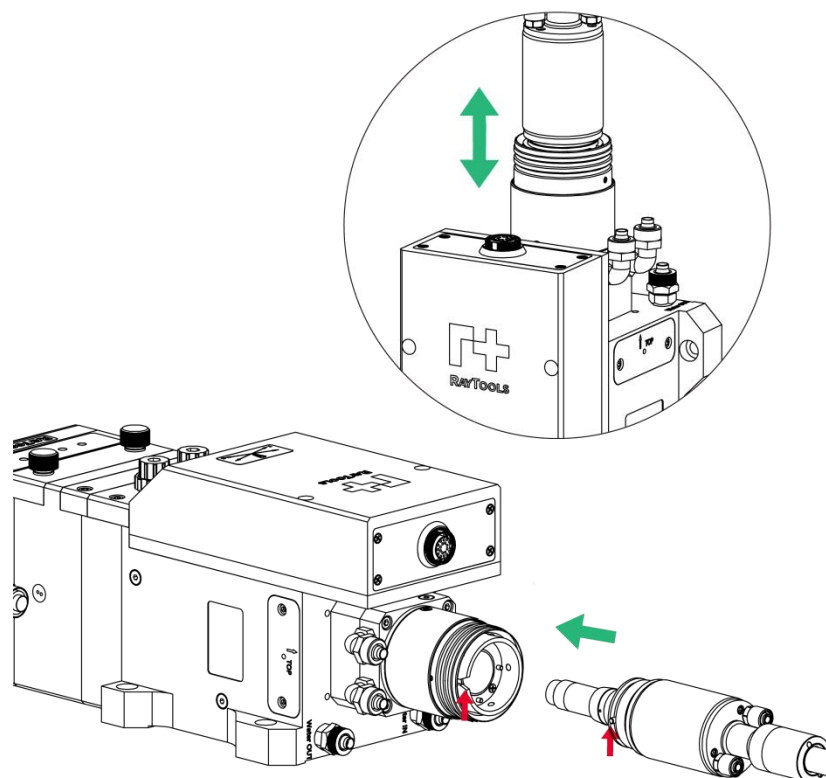

- Place the QD fiber head and cutting head horizontally.
- Remove the QD & QD interface dust proof cover
- Align the QD protrusion to the groove of the cutting head connector, then insert it into the laser head interface
- Press the fiber interface retaining ring, to make the QD protrusion completely match the groove, then loosen the retaining ring to lock the QD through natural rebound.

2.1.2 LOE Fiber Insertion

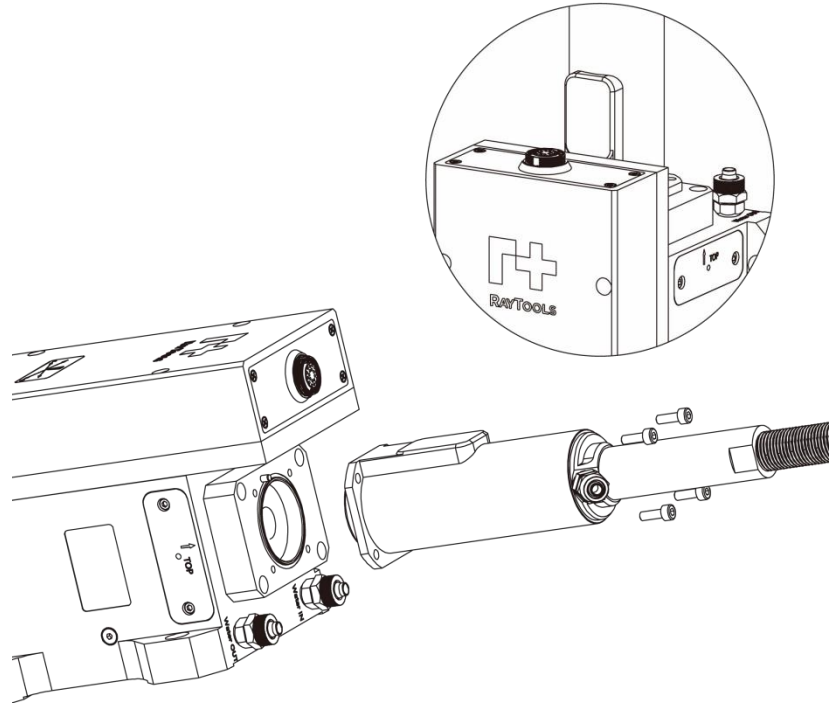

- Remove the dust cover of LOE adaptor.
- Align the locating pin holes of the fiber end and the laser head.
- Lock the fiber end and the laser head with locking screws tightened to the corresponding screw holes.
- Shake the fiber gently after locked, to confirm it is tightened prior to use.



It is recommended to use textured tape to seal the connection of female and male fiber interface after the installation is finished in order to prevent from dust as much as possible in critical dusty environment.

2.2 Mounting of Laser Cutting Head

The mounting of laser cutting head to machine tool is shown as below. Customers are advised to Install the laser head perpendicular to the bed surface as requested and make sure the laser head is locked, which is one of the premises to ensure the stable cutting.

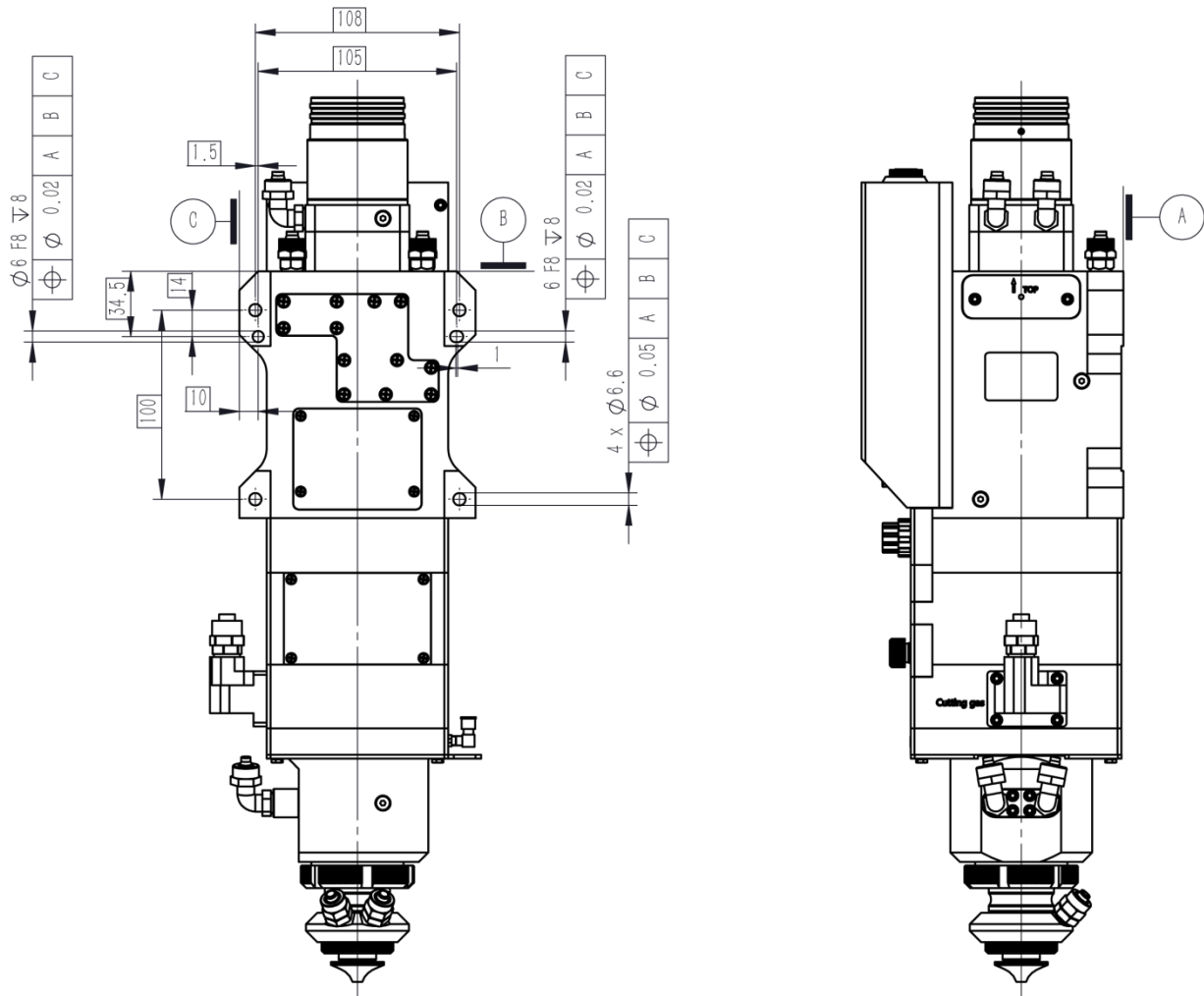

2.3 Earthing of Laser Cutting Head

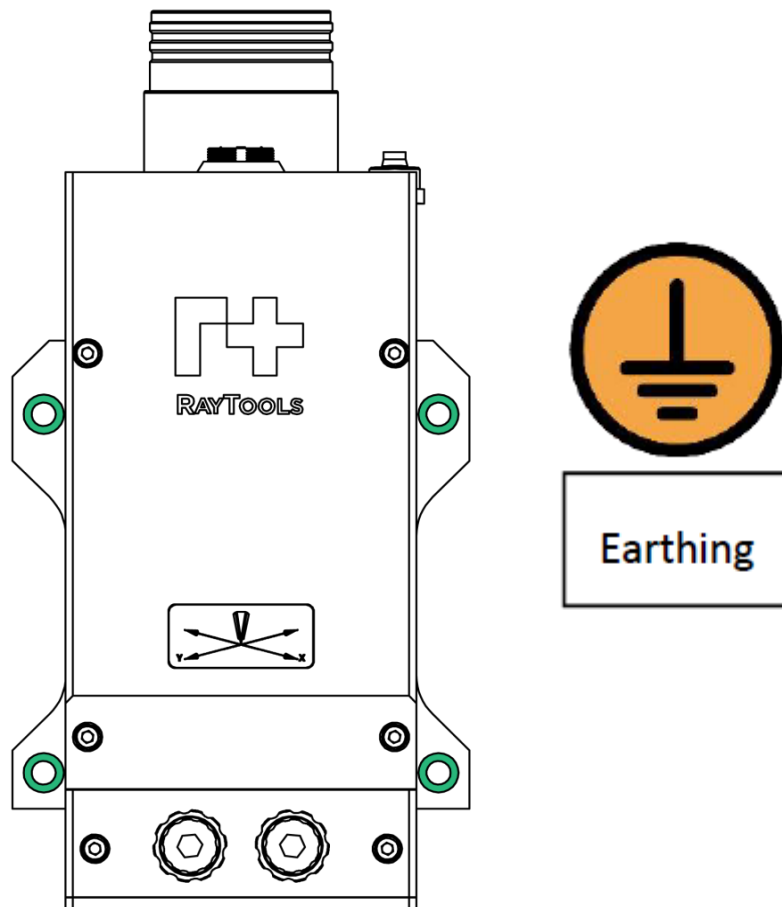

The shaking or vibration of cutting head due to incorrect earthing could cause damage to sensor mechanism and machine.

2.4 Inspection of 1st Top Cover Glass (1st Installation/Replacement of Fiber)

Maintenance or repair shall be implemented at dust free workstation.

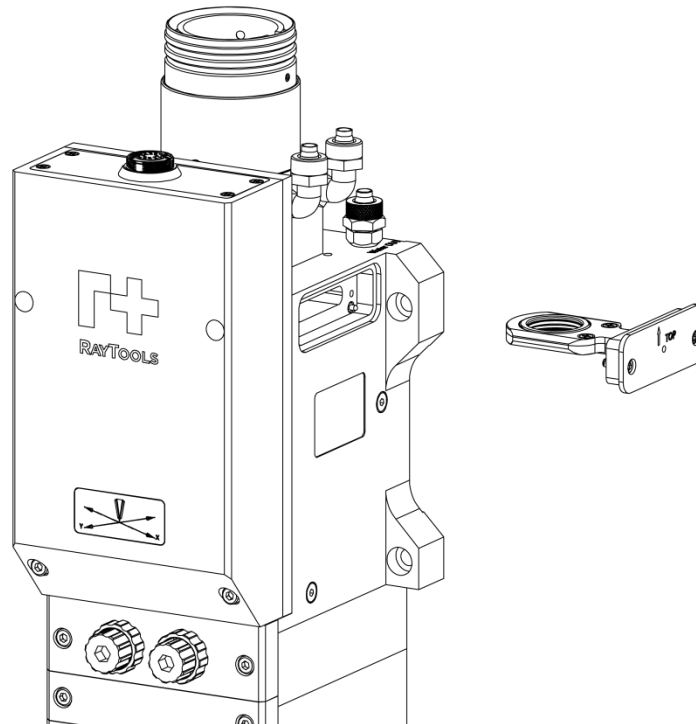

- Loosen bolts (1) and pull out the glass holder until you see the complete cover glass.
- Seal the openings of cutting head by textured tape immediately.
- Check if the top cover glass is clean. If not, blow the cover glass by clean compressed air until it is clean.



The cover glass shall be replaced if it cannot be cleaned or a damage happens.

2.5 Connection of Cooling Water and Assist Gas

2.5.1 Connection of Cutting Gas

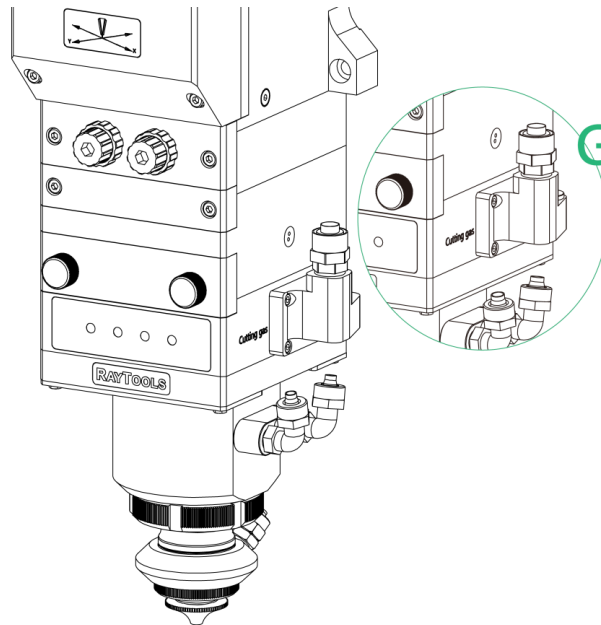

The impurity in cutting gas such as hydrocarbon and steam will damage the lens and cause cutting power fluctuation as well as inconsistencies between the sections of the work piece. The table below is the recommended cutting gas specification. The higher the purity of the gas, the better the quality of the cutting section.

Impurity can be filtered out in gas supply tube, but Oxygen and water vapor can permeate light path through nonmetal materials, which is the source of the appearance of dust and hydrocarbon. Stainless steel fittings are recommended, at the same time must use filters which can remove a minimum of 0.01 micron particle to purify.

A pressure gauge with a stainless steel diaphragm is recommended. Industrial pressure gauges suck in air. Rubber diaphragm produce hydrocarbon by aging or other factors.

Gas	Purity	Maximum content of water vapor	Maximum content of hydrocarbon
Oxygen	99.5%	<5 ppm	<1 ppm
Nitrogen	99.95%	<5 ppm	<1 ppm
Diameter of cutting gas pipe (Outer diameter)		ø12mm (G)	
Gas Pressure		Max. 25bar (2.5MPa)	

CAUTION: Gas interface cannot be replaced arbitrarily especially do not use PTFE TAPE. Otherwise the gas path will be blocked and cannot do normal cutting which will damage cutting head at the same time.

2.5.2 Connection of Cooling Water

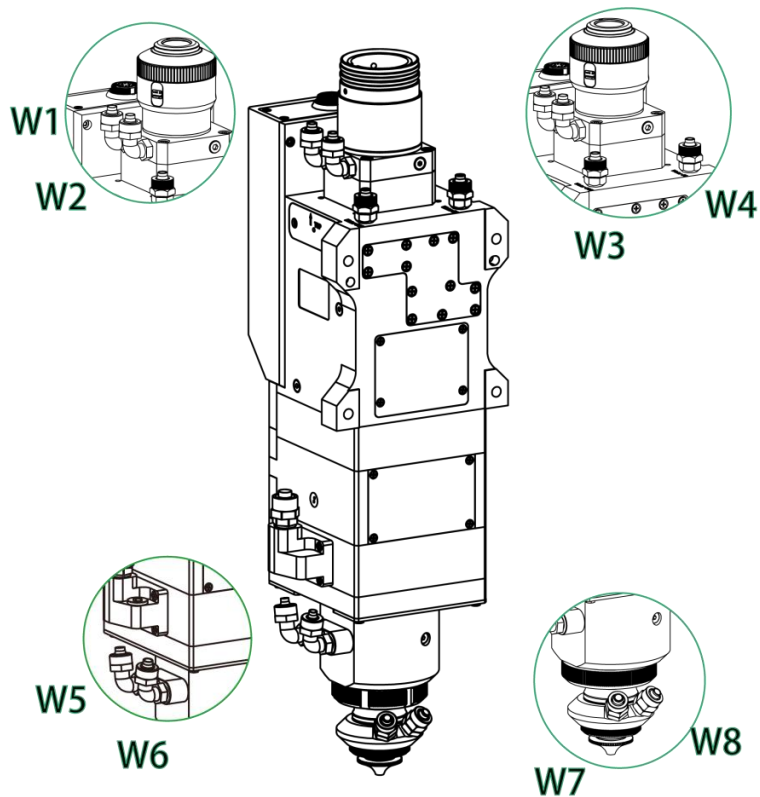

It is important to note that when the laser power is greater than 500W, it is recommended to use water cooling. The recommended water flow is suggested below. For the inlet and outlet please refer to the marks on the laser.

- Cooling pipe of fiber interface: W1, W2, Collimation module: W3, W4, Body: W5,W6.

The cooling water must comply with the technical standards in the table below.

Outer diameter of water hose	ø8mm
Minimum flow speed	1.5 l/min
Entry pressure	170-520kPa
Entry temperature	≥room temperature / > dew point
Hardness (relative to CaCO3)	<250mg/liter
PH range	6 to 8
Particle size allowed	Diameter less than 200 microns

3 System Installation and Commissioning

3.1 Auto Focus by 0-10V Analog

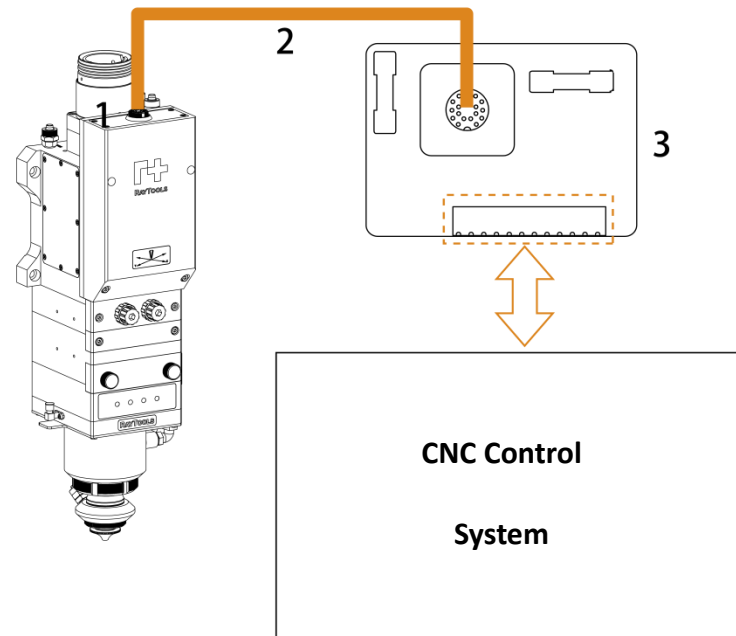

- Connect (1) the 19-pin interface of laser head with (3) I/O-CAN board by (2) the control cable
- Connect all necessary I/O interfaces with CNC
- Connect 24V power supply to the I/O-CAN board
- Complete configuration and commissioning according to the system instruction. With *Raytools* motion control system, user can select to use the default parameter.

I/O-CAN Board

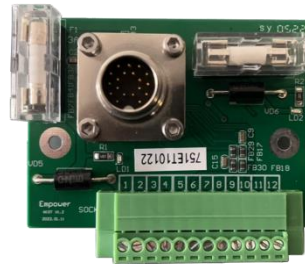

I/O-CAN Definition

Pin No.	Item	Definition
1	Power supply 24V	24V to power supply
2	Power supply 0V	0V to power supply
3	I/O 24V	24V to I/O
4	I/O 0V	0V to I/O
5	RS485+	485 Communication
6	RS485-	485 Communication
7	Input-Home	24V (Uperedge): Manual homing enable (Keep PNP while homing to prevent being failed) Else: Home disable
8	Input-Focus	24V (Uperedge): Focus enable Else: Focus disable
9	Output-Alarm	Floating (High Impedance State): Alarm 0V: no alarm
10	Output-Focus reached	0V: Focus reached Floating (High Impedance State): Focus unreached
11	Input-Analog +	0.3V-9.7V Auto focus
12	Input-Analog -	

Remark: connect Pin 11, Pin 12 by the complimentary shielded twisted pair.

Take the connection to *FSCUT* system as an example:

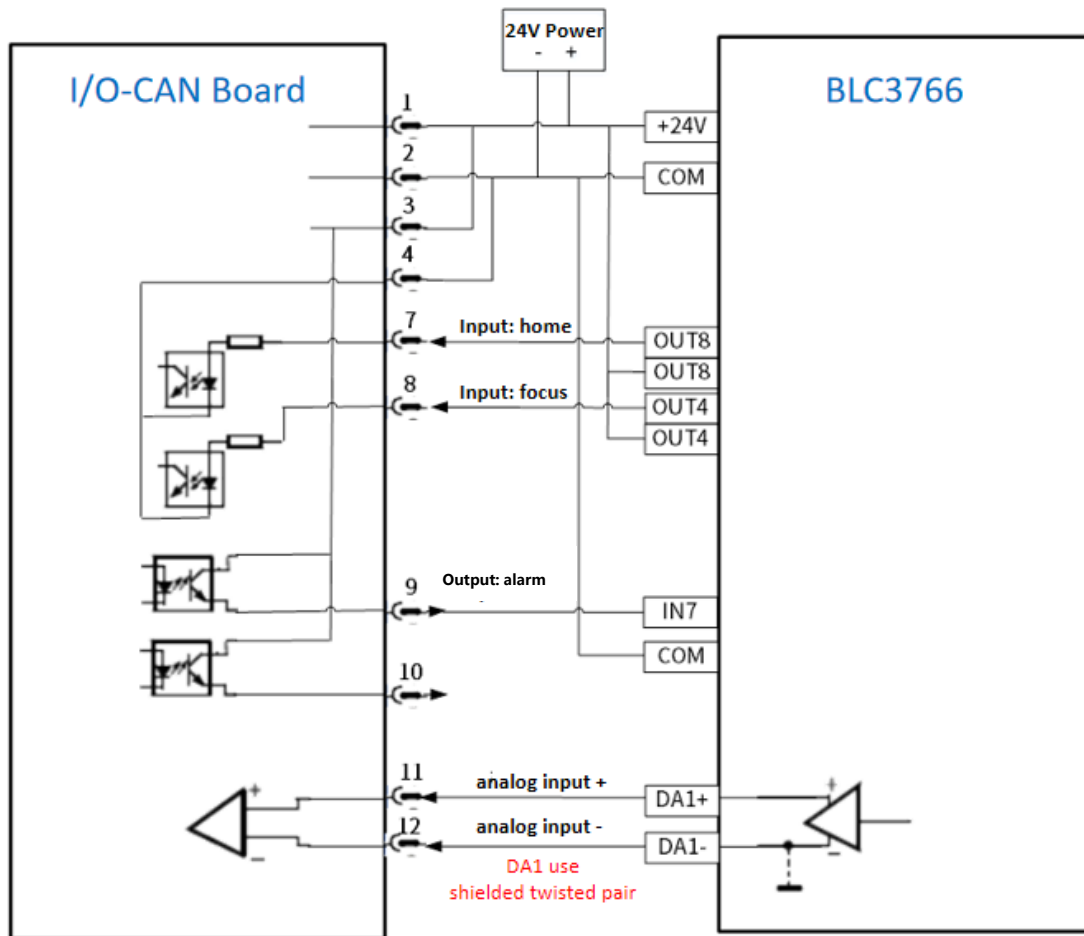

Wiring diagram

After the wiring is completed, enter the system setting. The following parameters are only for reference.

Optical configuration: **100:200**

Raytools system setting:

Laser head

Brand: Raytools

Model: BS15K

Focus control mode: 0-10V Analog output

Height sensor type: EDS On Board

Height sensor signal port: Slave ID4:Height Sensor Capaci

Focus adjmt

Laser Head Parameter

Voltage range (V) 0.3 ~ 9.7

Focal range (mm) 40 ~ -40

Voltage of zero focus 5 v

Focusing enable delay 300 ms

Return to origin delay 10000 ms

Focus analog output: Slave ID4: AO_1

Focus enable: Slave ID4: DO_3

Return to origin: Slave ID4: DO_5

Cutting head alarm: Slave ID4: DI_16

Shield cutting head alarm

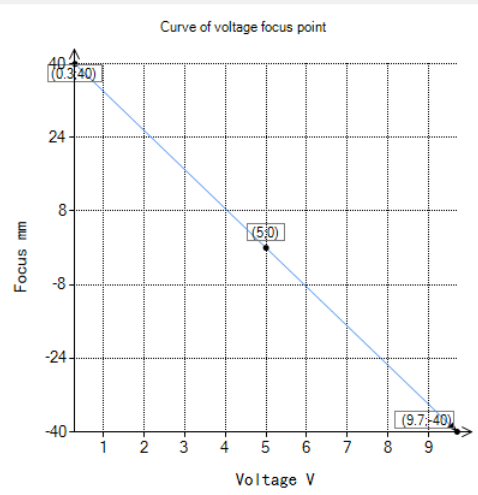

Curve of voltage focus point

FSCUT system setting:

Focus Control

Enable

The fourth
 Precitec
 HighYAG
 Procutter-Zoom
 Ecot Ext Board[No Co

Range: From -40mm to 40mm

Focus voltage(DA): DA1 **Analog**

DA voltage range: From 9.7V to 0.3V

Cut-off voltage: 0.3V

DA delay: 10ms

Confirm focus(out): 4 **Enable focus**

Confirm delay: 300ms

Feedback voltage(AD): No Use Enable temp. compensation

Function selection (ou): 0

Return Origin(out): 8 **Home**

Return Origin delay: 10000ms



Focus z-direction



The connections and settings may differ from one CNC control system to another. Once the setting is modified, the corresponding wiring method may need to be changed.

3.2 Auto Focus by EtherCAT

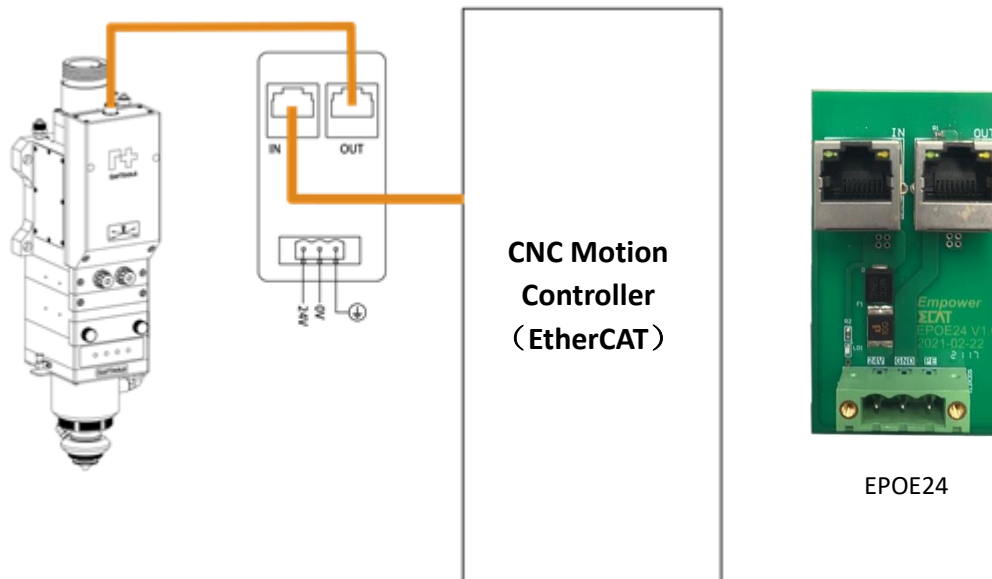

- Connect 24V power supply to the I/O board (EPOE24)
- Connect by network cable as shown above
- Complete configuration and commissioning according to the system instruction

EPOE24 Definition

No.	Definition	Remark
IN	Input-Interface	Signal input
OUT	Output-Interface	Signal output
24V	Power supply 24V	24V to power supply
GND	Power supply 0V	0V to power supply
PE	Earthing	For earthing

3.3 PC-based Monitoring Software

- Start the software and operate connection according to the instruction.
- Set value based on actual needs.

Examples as below:

Item	Remark	Set Value
Zero Focus Offset	To correct according to actual zero focus position	
Alarm Temp-Top Cover Glass	Alarm threshold 45°C	45°C
Alarm Temp-Bottom Cover Glass	Alarm threshold 45°C	45°C
Alarm Temp- Focus Lens	Alarm threshold 45°C	45°C
Alarm Temp- Cavity	Alarm threshold 45°C	45°C
Alarm Pressure-Cavity	Alarm threshold 1.5 bar	1.5 bar

3.3.1 Download and Installation

Please contact Raytools to get the installation pack for software installation.

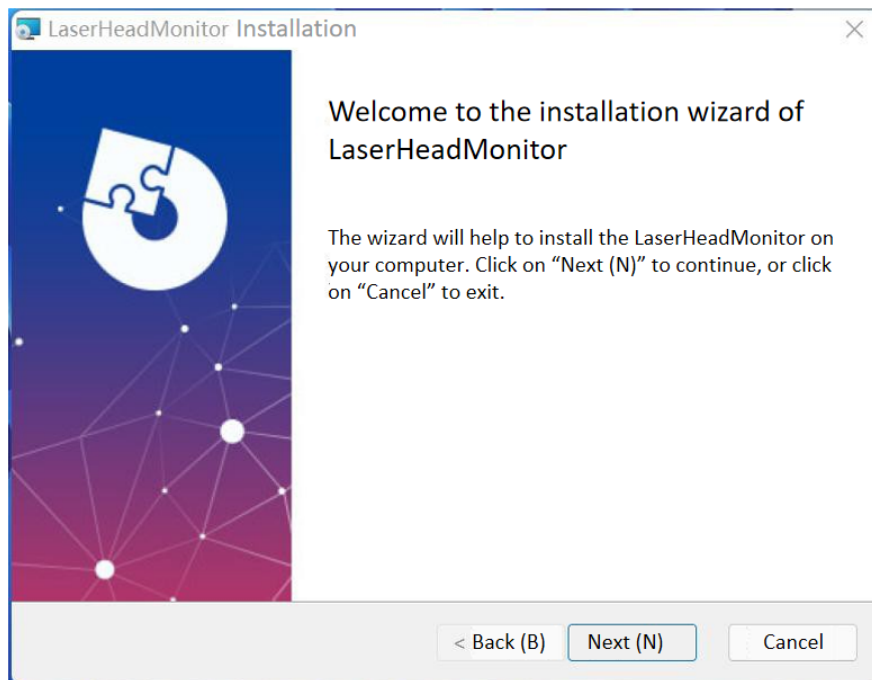

Open the monitoring software and there will be a hover ball on top of the display, double click the hover ball to display detailed information.

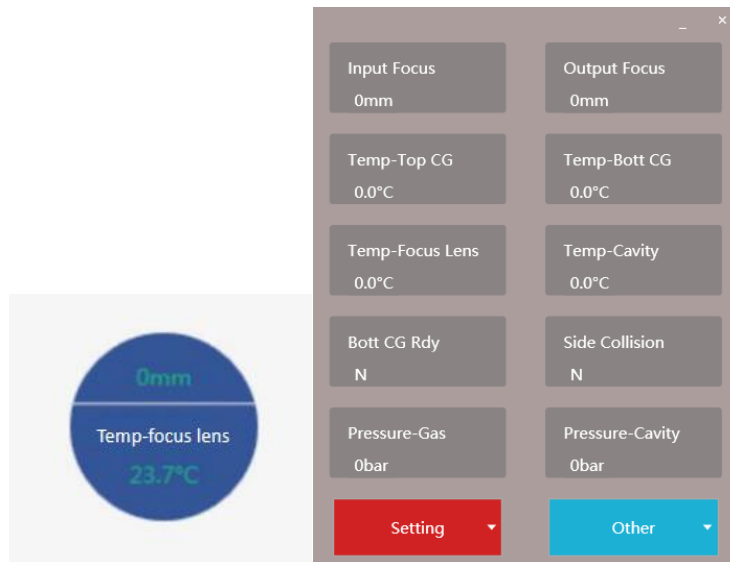

3.3.2 Connection

Connect laser cutting head by WIFI or USB to display real-time data of cutting head. USB connection is recommended to secure more stable connection.



Real-time sensor data can be monitored manually. If an alarm occurs in the cutting head, history data for 1 minute prior to the alarm is auto-recorded.

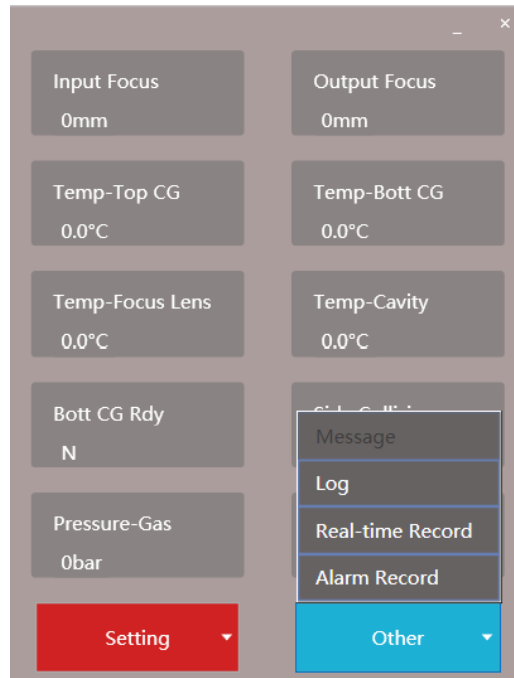

Real-time sensor data can be monitored manually. If an alarm occurs in the cutting head, history data for 1 minute prior to the alarm is auto-recorded.

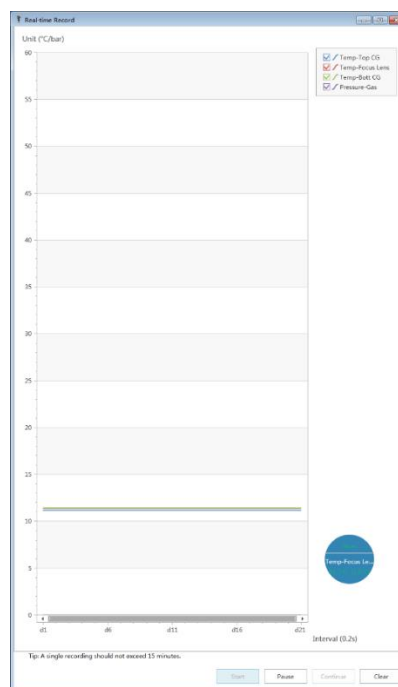

Note: The RS-485 to USB cable will be attached with the head to connect with HMI PC.

4 Beam Alignment and Zero Focus Correction

4.1 Beam Alignment

Cutting quality in a great extent depends on whether the lens is in the middle. If the lens is not in the middle, the laser beam may contact with nozzle or inner wall to produce high temperature deformation. Lens alignment operation should be considered when nozzle is replaced or the cutting quality declines.

Lens alignment of laser cutting head can be finished by adjusting focus lens, X-Y direction. The X/Y adjusting knob is located above bottom cover glass as shown below. Adjusting the 2 knobs until the beam is located in the middle of nozzle. Make sure the laser beam output from the center of nozzle. A method commonly used is tape dotting method as below:

- Fix the cutting head with a big size nozzle (tip size shall be larger than beam size) or adjust to nearly zero focus.
- Pick a scotch tape, flatten it and stick it to the nozzle tip.
- Open the red light of the laser. Find and observe the position of red light in the scotch tape.
- Shoot laser at low power to check beam penetration size. Beam penetration shall be circle and located in the nozzle tip center.
- Adjust the 2 X/Y adjusting knobs to get beam aligned. The max X/Y adjusting range is roughly from -1.5mm to +1.5mm.
- Tear off the tape and check the shooting hole position in tape.
- Repeat the above steps to find out relatively centered position.

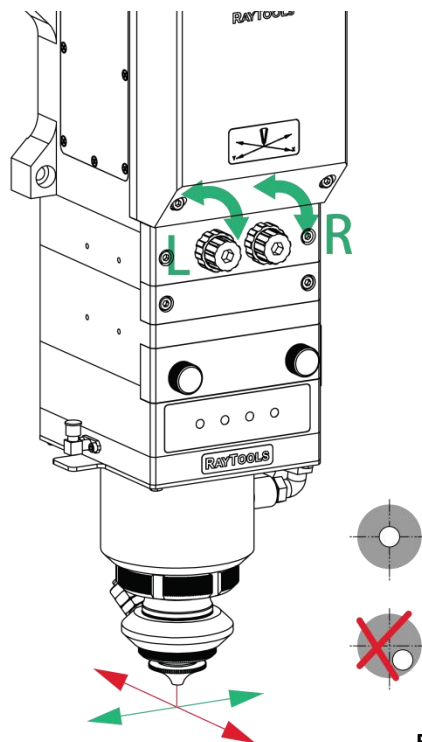
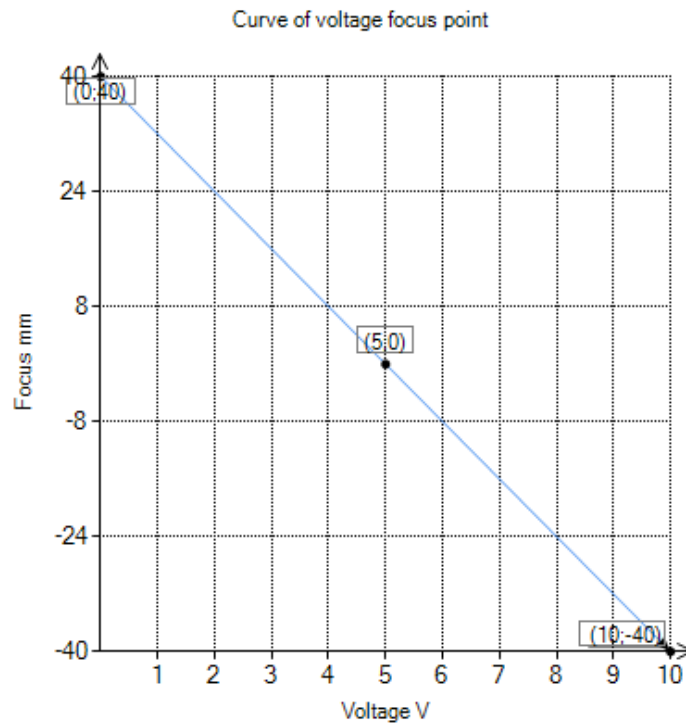

Figure 4.1— Beam Adjustment

4.2 Focus Position Setting

Focus & Voltage Curve



Note:

1. CL100mm/FL200mm: 0.3V corresponds to +40mm. 9.7V corresponds to -40mm.
2. Mechanical and optical manufacturing tolerance, matching tolerance between imaging proportion of optical component and optical fiber will have other effects on the actual focus position.
3. Adjust the focus offset according to the actual situation.

5 Maintenance

5.1 Cleaning Lens

It's necessary to maintain lenses regularly because of the characteristic of laser cutting process. Cleaning to the cover glass once a week is recommended. The collimation lenses and focusing lenses are recommended to be cleaned once every 2~3 months. In order to facilitate the maintenance of the cover glass, the cover glass holder adopts a drawer type structure.

Tools: Dust-proof gloves or fingertip, polyester swab, absolute ethanol, rubber gas blow (purely compressed air).

Cleaning instruction:

- To put fingertip onto left thumb and index finger.
- Spray absolute ethanol onto the polyester swab.
- Hold the edge of the lens with left thumb and index finger gently. (note: avoid touching the surface of the lens by fingertip in case of trace)
- Hold the lens to face eyes by left hand and hold the polyester swab by right hand. Wipe the lens gently in single direction, from bottom to top or from left to right (Should not wipe back and forth in case of secondary pollution to lens) and use rubber blow (purely compressed air) to blow the surface of the lens. Both surfaces should be cleaned. After cleaning, make sure that there is no residual like detergent, floating ash, foreign matters and impurities.

5.2 Removal and Installation of Lenses

The whole process needs to be completed in a dust free room. Wear dust-proof gloves or fingertips when removing or installing the lenses.

5.2.1 Removal and Installation of Bottom Cover Glass/Protection Glass

The cover glass is wearing part which needs to be replaced once it is damaged.

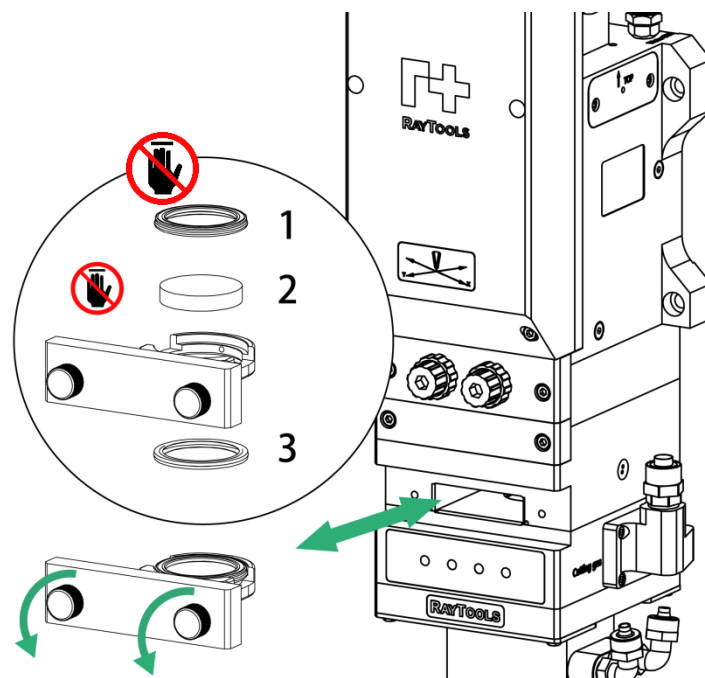

- As shown above, loosen the 2 bolts to pull out cover glass holder by pinching 2 edges of drawer type holder.
- Seal the mounting openings by textured tape immediately.
- Remove the pressing ring (1) and cover glass (2) after wearing fingertips
- Clean the cover glass holder and seal ring (3). The elastic seal ring (3) should be replaced if it is damaged.
- Install the cleaned or new cover glass (regardless of the front or back surface) into the holder of cover glass.
- Install the pressing ring.
- Insert the cover glass holder back to the laser head and tighten the bolts.



It is not allowed to pull out the edge of seal ring directly as it is very easy to damage the seal ring.

Please wear the clean gloves or fingertips.

5.2.2 Removal and Installation of Middle Cover Glass/Protection Glass

The cover glass is wearing part which needs to be replaced once it is damaged.

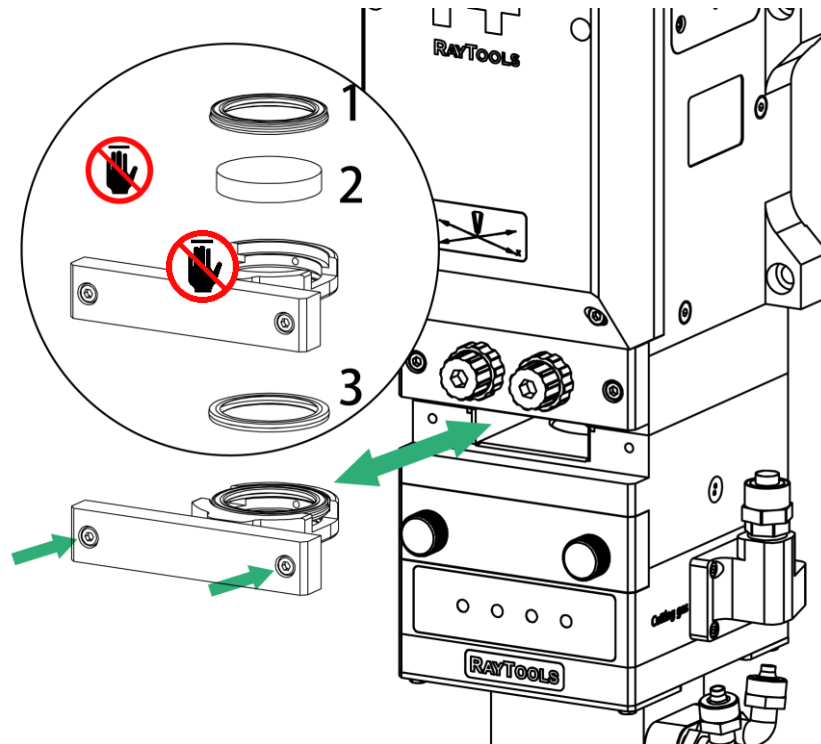

- As shown above, loosen the 2 bolts to pull out cover glass holder by pinching 2 edges of drawer type holder.
- Seal the mounting openings by textured tape immediately.
- Remove the pressing ring (1) and cover glass (2) after wearing fingertips
- Clean the cover glass holder and seal ring (3). The elastic seal ring (3) should be replaced if it is damaged.
- Install the cleaned or new cover glass (regardless of the front or back surface) into the holder of cover glass.
- Install the pressing ring.
- Insert the cover glass holder back to the laser head and tighten the bolts.



It is not allowed to pull out the edge of seal ring directly as it is very easy to damage the seal ring. Please wear the clean gloves or fingertips.

5.2.3 Removal and Installation of Focus Lens

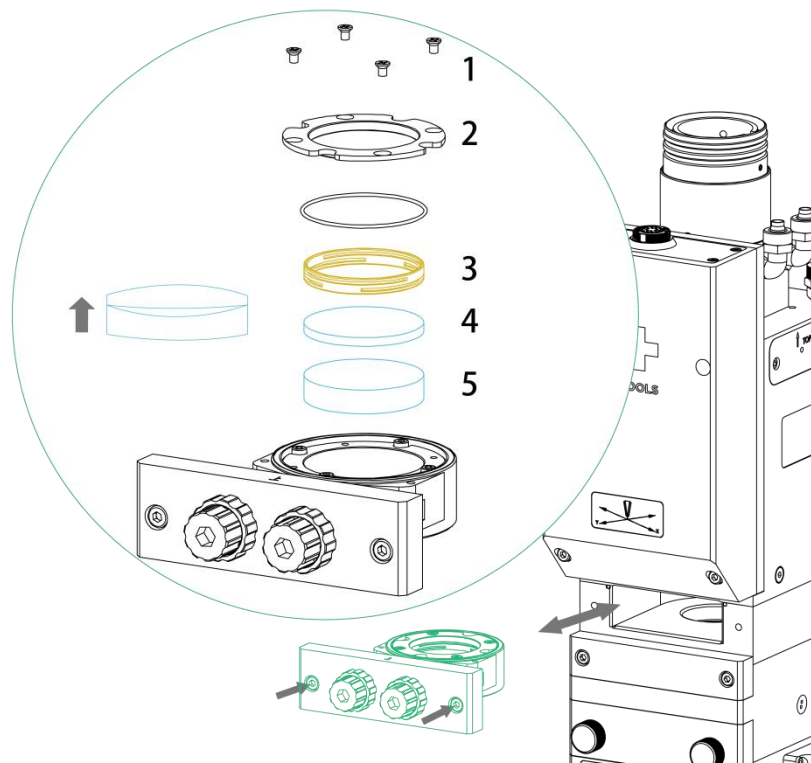

- Clean all dusts on the laser head surface.
- Loosen the 2 bolts as above to pull out focus lens holder.
- Seal the focus lens and mounting openings by textured tape immediately.
- Move the focus lens holder to a dust free room and loosen the bolts (1). Remove the cover (2), pressing ring (3) and focus lenses (4--biconvex one and 5—meniscus one) in sequence.
- Replace or clean the focus lenses (as per direction above, the small curved face of biconvex lens shall be close to concave face of meniscus lens).
- Put focus lenses (5—meniscus one and 4--biconvex one) and pressing ring (3) into the lens holder and cover it by cover (2). Tighten it by bolts (1).
- Insert the focus lens holder into the cutting head and tighten the bolts.



Check if the beam is aligned. If not, please do the alignment as per chapter 4.1.

5.2.4 Removal and Installation of Collimation Lens

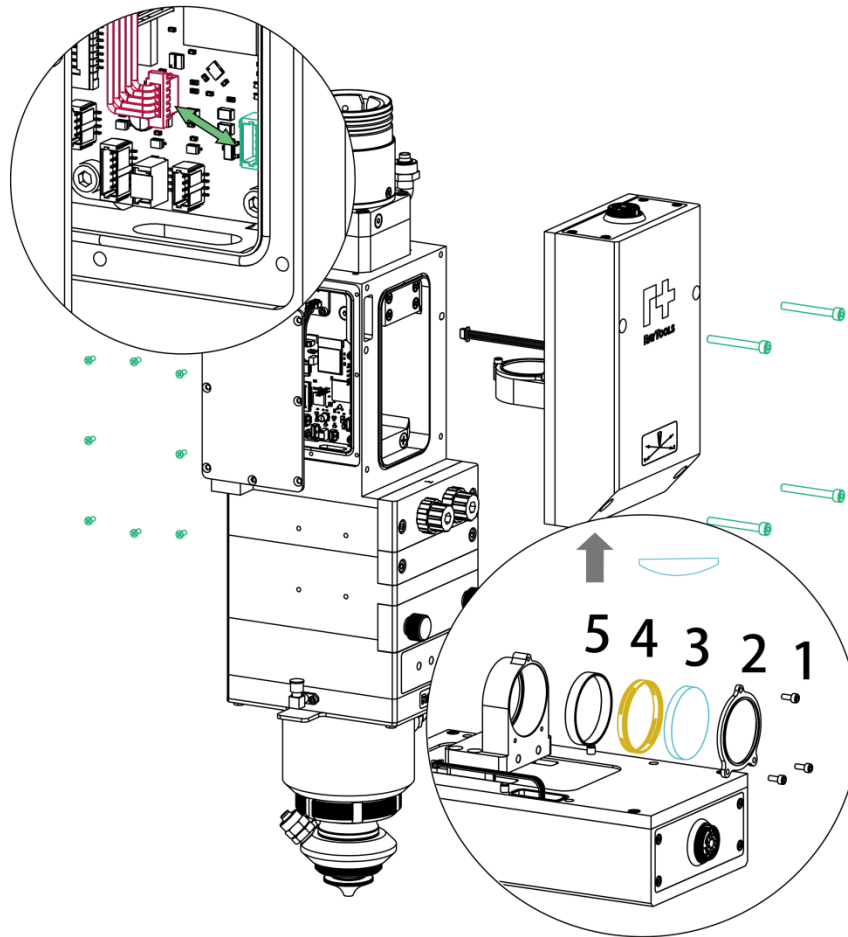

- Remove the laser head and clean all dust on the laser head surface in dust-free room, then move it into the clean bench.
- As shown above, loosen the eight side-cover screws, then remove the side cover and 5PIN terminal blocks
- As shown above, loosen the four screws to remove the entire collimation module.
- Loosen the bolt (1) and remove the cover (2), collimation lens (3), spring pressure ring (4) and ring (5) in sequence
- Replace or clean the collimation lens (The lens plane faces the cover (2), according to the above figure)
- Put the collimation lens (3) on the lens holder and cover it with a lid (2), then tighten it with bolts (1).
- Put modules on the cutting head back and tighten the bolt.
- Insert 5PIN terminal blocks and the side cover and lock the screw.



Check if the beam is aligned. If not, please do the alignment as per chapter 4.1.

5.2.5 Replace or Clean the 2nd Top Cover Glass

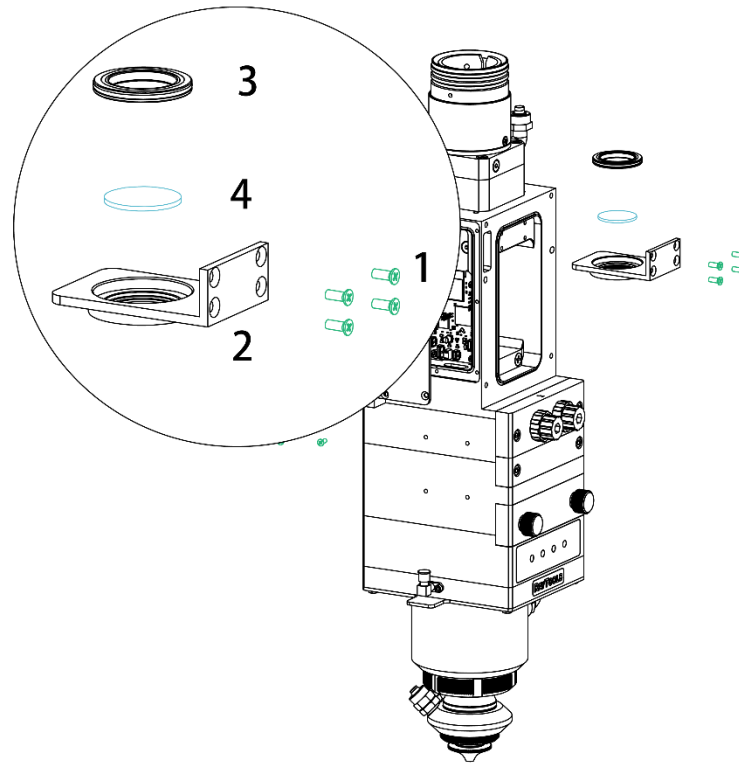

- Remove the collimation module according to 5.2.4.
- As shown above, loosen 4 screws and remove the protective lens holder (2).
- Remove the protective lens washer (3) and cover glass (4) in sequence.
- Replace or clean the cover glass (4).
- Clean the protective lens holder (2) protective lens ring (3) and its sealing ring. The seal ring should be replaced if damaged.
- Place the cover glass (4) in the protective lens holder (2), and cover it with the washer (3)
- Put the holder of the cutting head back and tighten the bolt
- Install the entire collimation module according to 5.2.4



Check if the beam is aligned. If not, please do the alignment as per chapter 4.1.

5.3 Replace Ceramic Body and Nozzle

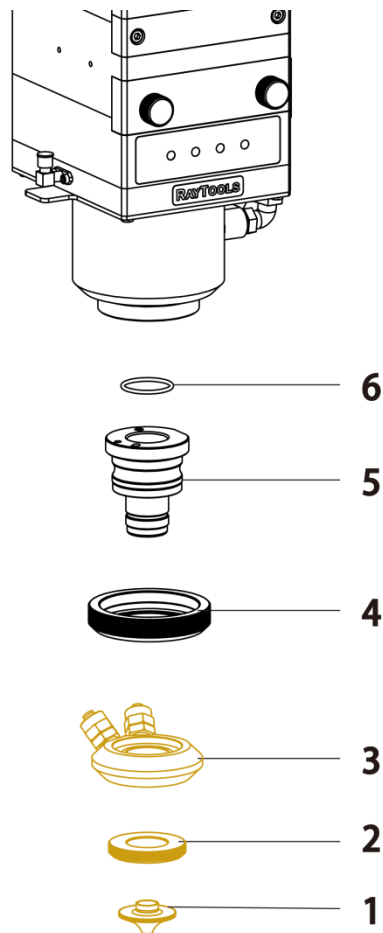

The nozzle is required to be replaced if it gets crash or damaged by laser beam. The dirt on ceramic body is required to be cleaned or to replace the ceramic body if it gets crash.

- Unscrew the nozzle (1) and remove washer (2) and cooling module (3).
- Press the ceramic body (5) upward by hand to make it fixed without deflection and then unscrew the retaining ring (4).
- Align the pin hole of the new ceramic body with the locating pin. Press the ceramic body (5) upward by hand and tighten the retaining ring (4).
- Install the cooling module (3) and washer (2). Screw the nozzle (1) and get it properly tightened.
- Do the capacitance calibration once again after replacing the nozzle or ceramic body.



Only tighten the nozzle and retaining ring by hand (without tools) otherwise it could damage the ceramic body.



Keep the contact surface of all parts clean.

6 Consumables

Name	Technical Data	Material Code
Fiber Interface	QBH	211FIA3003
	Q+	211FIA4003
	QD	211FIA3007
	LOE3.2	120BS5002A
Collimation Lens	Biconvex spherical lens	3250010280
	Meniscus spherical lens	3250010281
Focus Lens	Biconvex spherical lens	3250010433
	Meniscus spherical lens	3250010420
Cover Glass	D24.9 x 1.5	211LCG0086
	D37 x 7	211LCG0078
Nozzle	2D Single layer M11 - \varnothing 1.2	120GJT5112
	2D Single layer M11 - \varnothing 1.3	120GJT5113
	2D Single layer M11 - \varnothing 1.5	120GJT5115
	2D Single layer M11 - \varnothing 1.7	120GJT5117
	2D Single layer M11 - \varnothing 1.9	120GJT5119
	2D Single layer M11 - \varnothing 2.1	120GJT5121
	2D Single layer M11 - \varnothing 2.3	120GJT5123
	2D Single layer M11 - \varnothing 2.5	120GJT5125
	2D Double layer M11 - \varnothing 1.2	120GJT7212
	2D Double layer M11 - \varnothing 1.3	120GJT7213
	2D Double layer M11 - \varnothing 1.4	120GJT7214
	2D Double layer M11 - \varnothing 1.6	120GJT7216
	2D Double layer M11 - \varnothing 1.8	120GJT7218
	2D Single layer M11 - \varnothing 1.5	120GJT9115
	2D Single layer M11 - \varnothing 2.0	120GJT9120
	2D Single layer M11 - \varnothing 3.0	120GJT9130
	2D Single layer M11 - \varnothing 4.0	120GJT9140
	2D Single layer M11 - \varnothing 5.0	120GJT9150
	2D Single layer M11 - \varnothing 6.0	120GJT9160
	2D Single layer M11 - \varnothing 7.0	120GJT9170
Ceramic Body	D41- M11	120515089A