

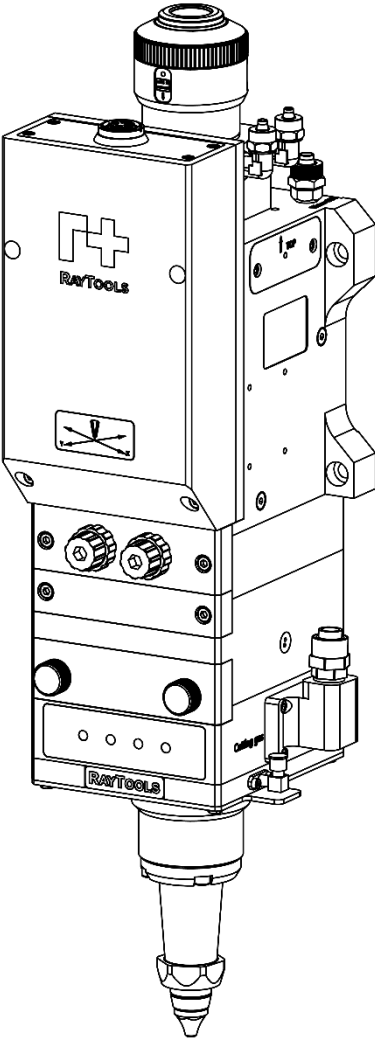

BS08K SERIES

8kW 3D Laser Cutting Head - User Manual



Document History

Edit date	Version	Topic, revision, action taken
2024/5/13	V1.0	First edition

Thank you for choosing our product!

This manual describes the installation and commissioning of laser cutting head in details so that you can use this product quickly. You can consult us directly for more details.

Due to the continuous updating of product functions, the product you receive may differ from the introduction in this manual in some aspects.

We reserve all rights in this document including the issued patents and other registered commercial ownership related to this document. It is strictly prohibited to use this document in an improper way especially to copy and disseminate it to third parties.

If you find any errors in this document, please inform us as soon as possible. The data contained in this manual is only used to describe the product and shall not be regarded as a statement of security interest.

For the benefit of our customers, we will constantly try to ensure that the products we develop comply with the latest technology.

Raytools AG

Email: sales@raytools.com

Website: www.raytools.ch

Disclaimer

- We reserve the right to change the design in order to improve the quality or expand the application or comply to manufacturing workmanship.
- We will not bear any responsibility for losses and accidents caused by wrong operation or improper handling of our products.
- Dismantling of product will lose all warranty claims excluding the normal replacement of worn parts and components required for maintenance or commissioning operations.
- Unauthorized modification of products or use of non-original spare parts will directly lead to the invalidation of warranty and liability exemption.
- It is recommended to only use the spare parts provided by us or submit them to us or the designated professional team for installation.

Use Regulations



- Ensure that the product is used in a dry environment.
- Ensure that the product is used in the environment required by EMC standards.
- The product is only allowed to run within the parameters specified in the technical data.

Personnel Responsibilities

- Be familiar with the basic provisions of work safety & accident prevention and have received equipment operation guidance.
- Read and understand basic safety instructions and operations.
- You must have studied the relevant regulations and safety instructions and understand the possible hazards.
- Comply with relevant regulations and implement corresponding protective measures.

Safety Instructions

Prevent Electric Shock

-  Parts of the laser head such as nozzle, sensor, sensor interface and attached fasteners may not be fully protected by the ground wire due to function fault. These parts may have low voltage. When installing electrical equipment, please pay attention to taking anti electric shock measures for relevant personnel.
-  Note that the equipment shall be grounded as specified.

Guard against Danger

- Never put your hands or other body under the laser head.
- Repair and maintenance work can only be carried out after the power is turned off.
- Do not exceed the specified maximum pressure.
- It must be ensured that the laser head is in normal condition at all times.
- All fasteners such as bolts and nuts must be tightened.



Laser Caution

- Avoid direct laser radiation or scattering to the skin.
- Do not stare at the laser beam even when wearing optical equipment.
- Use special laser protective eyeglasses that meet the requirements of safety standards IEC 60825-1.

Prevent Waterway Corrosion

- In order to avoid corrosion, use the specified coolant and comply with relevant requirements and specified maintenance intervals.

Noise Prevention

- The corresponding measures shall be specified or explained and observed in order to prevent personnel from being harmed by noise when the cutting air pressure is high.

Storage and Transportation

- Observe the storage temperature range allowed by the technical data.
- Take reasonable measures to prevent fire, vibration or impact.
- Do not store in or near the magnetic field.

Contents

1	Product Summary	1
1.1	View (with QBH Interface).....	1
1.2	Structure (with QBH Interface).....	2
1.3	LED.....	3
1.4	Technical Datasheet.....	4
1.5	Mechanical Size	5
1.6	Physical Interface.....	6
2	Mechanical Installation	7
2.1	Fiber Insertion	7
2.2	Mounting of Laser Cutting Head	8
2.3	Earthing of Laser Cutting Head.....	9
2.4	Inspection of Top Cover Glass (1 st Installation/Replacement of Fiber)	10
2.5	Connection of Cooling Water and Assist Gas	11
2.6	Connection of Cutting Head Cable	14
3	System Installation and Commissioning	15
3.1	Auto Focus by 0-10V Analog.....	15
3.2	Auto Focus by EtherCAT	19
3.3	Mobile APP (APPX-BS)	20
3.4	PC-based Monitoring Software	23
4	Beam Alignment and Zero Focus Correction	25
4.1	Beam Alignment	25
4.2	Zero Focus Correction.....	26
5	Maintenance	27
5.1	Cleaning Lens.....	27
5.2	Removal and Installation of Lenses	28
5.3	Replace Ceramic Body and Nozzle	32

1 Product Summary

1.1 View (with QBH Interface)

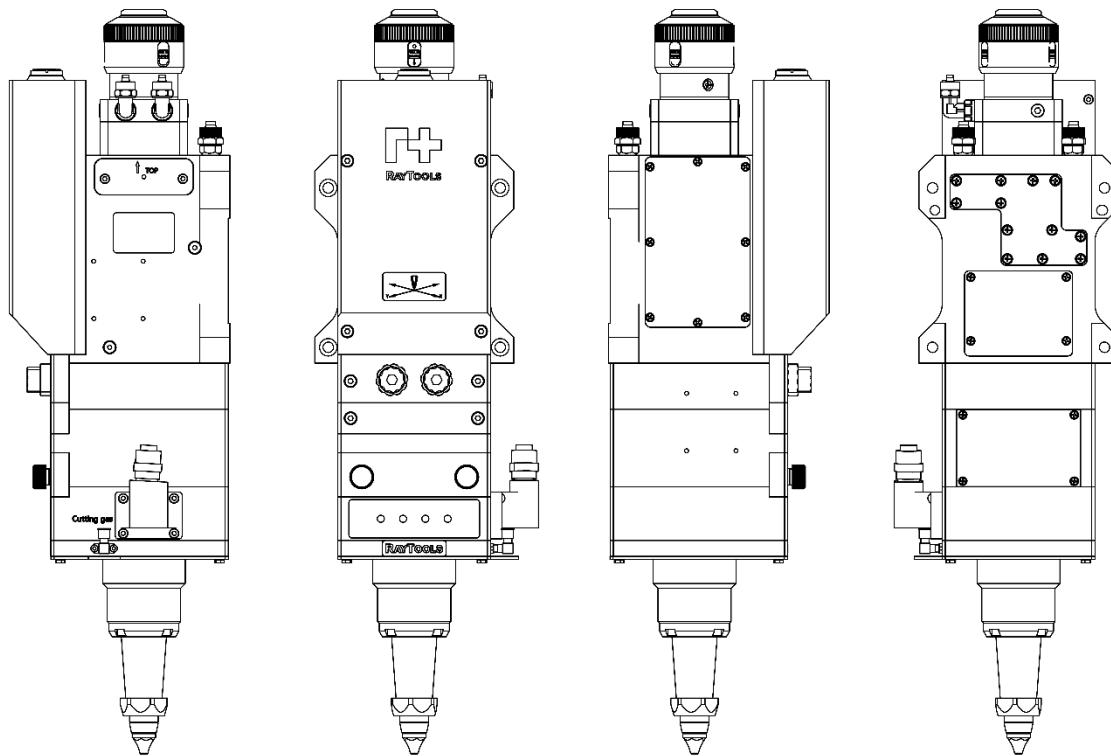

1.2 Structure (with QBH Interface)

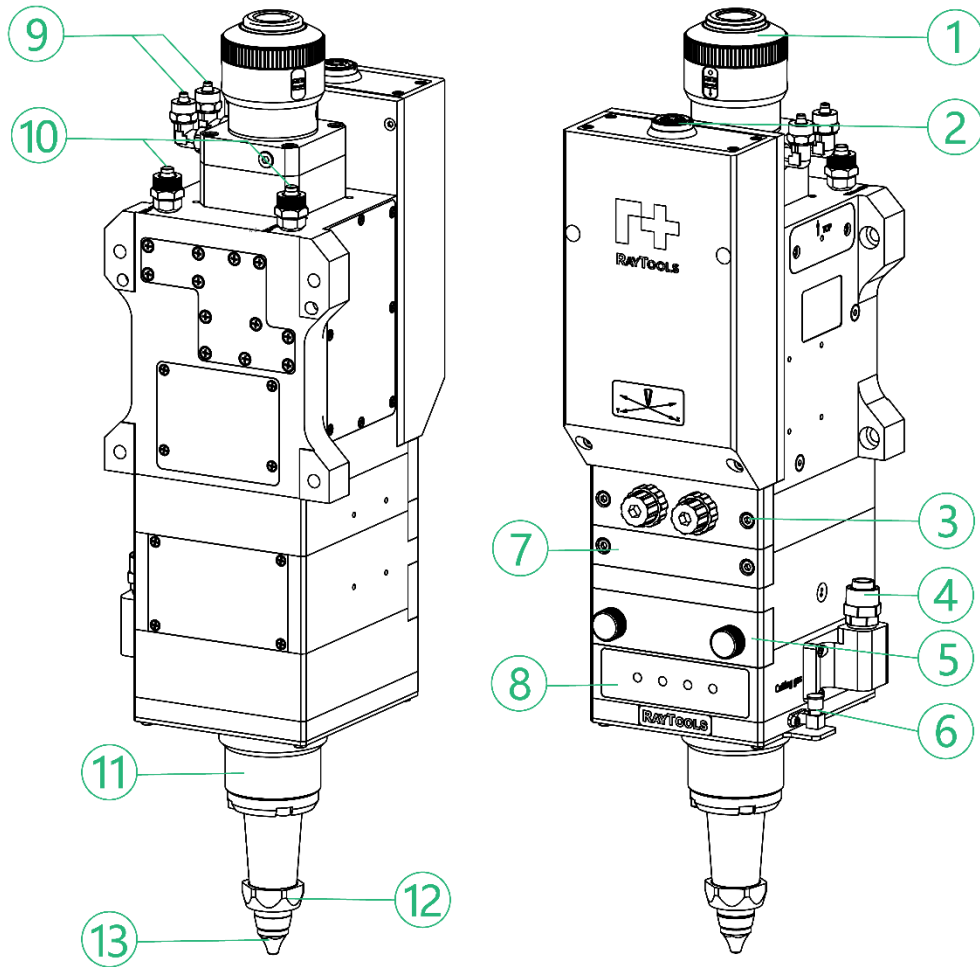

1 Fiber Interface

2 Control Interface

3 Focus Module/XY Alignment

4 Cutting Gas Interface (□10)

5 Bottom Cover Glass Assy

6 Pre-amplifier Interface

7 Middle Cover Glass Assy

8 LED

9 & 10 Water Cooling Interface (□6)

11 TRA (Nozzle Assy)

12 Ceramic Ring

13 Ceramic Body & Nozzle

1.3 LED

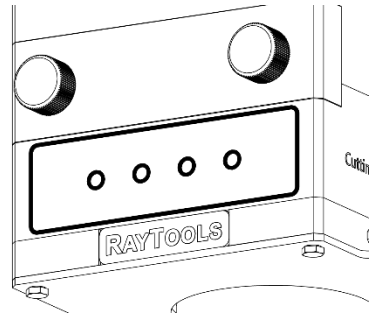

LED Status Definition (from left to right)

LED No.	LED Status	Status Definition
LED 1	Light off	Focus not homed or homing failed
	Green on	Running normally
	Green blinks	Focus motor homing
	Red on	Cavity fault
LED 2	Light off	Dew point alarm (closable)
	Green on	Running normally
	Red on	Abnormal temperature of top cover glass/ temperature rise alarm
	Red blinks	Abnormal temperature of top cover glass/ temperature rise precaution
LED 3	Light off	Cavity pressure alarm
	Green on	Running normally
	Red on	Abnormal temperature of focus lens/ temperature rise alarm
	Red blinks	Abnormal temperature of focus lens/ temperature rise precaution
LED 4	Light off	Bottom cover glass not ready for operation
	Green on	Running normally
	Red on	Abnormal temperature of bottom cover glass/ temperature rise alarm
	Red blinks	Abnormal temperature of bottom cover glass/ temperature rise precaution

Remark: 4-green LED and 4-red LED will blink alternately while online upgrading.

1.4 Technical Datasheet

Model	BS08K
Wavelength	1080nm
Fiber Interface	QBH
Power Rating	8kW
Collimation Length (fC)	100mm
Focusing Length (fF)	220mm
NA max	0.13
Auto Focus Range	-40mm...+40mm
Beam Alignment Range	-1.5mm...+1.5mm
Mounting Size of Cutting Head	4xM6
Mounting Size of Preampfier	4xM3
Cutting Gas	ø12, max. 25bar
Water Cooling	ø6, max. 5bar, min. 1.5L/min
Operating Voltage	24V±10%, max. 4A
I/O Interface (19-Pin)	Output current must be less than 30mA
Operating Temperature	5°C~55°C
Humidity	30%~95%, without condensing
Weight	6.5kg~7.0kg

1.5 Mechanical Size

Optical Configuration: 100:220

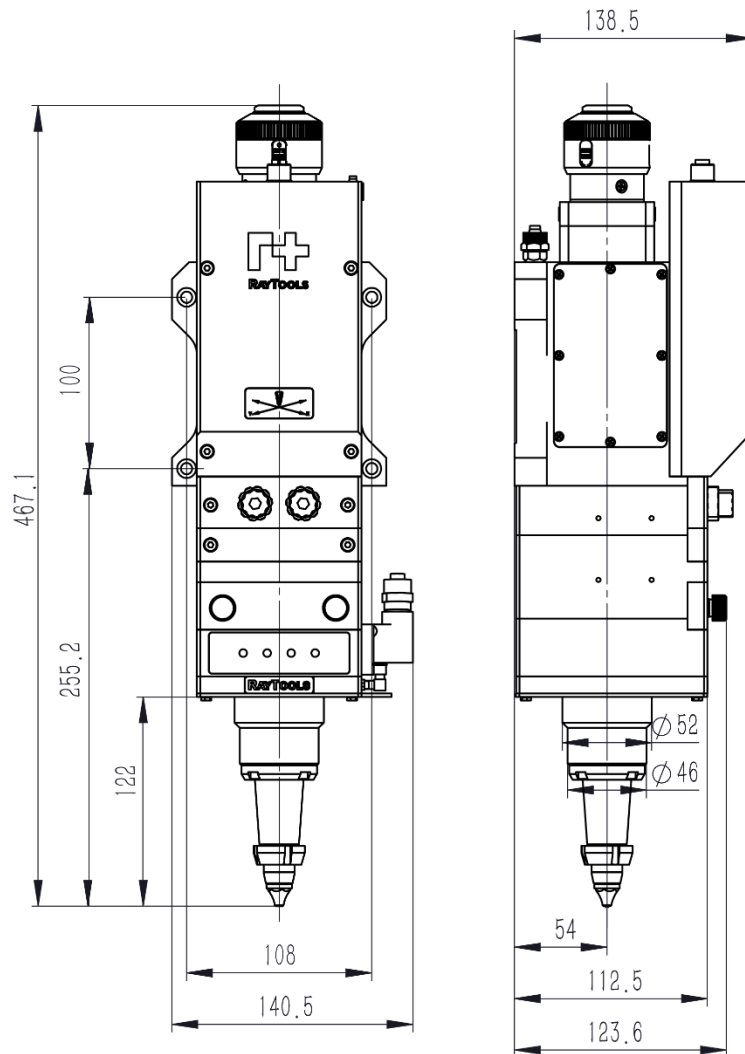

1.6 Physical Interface

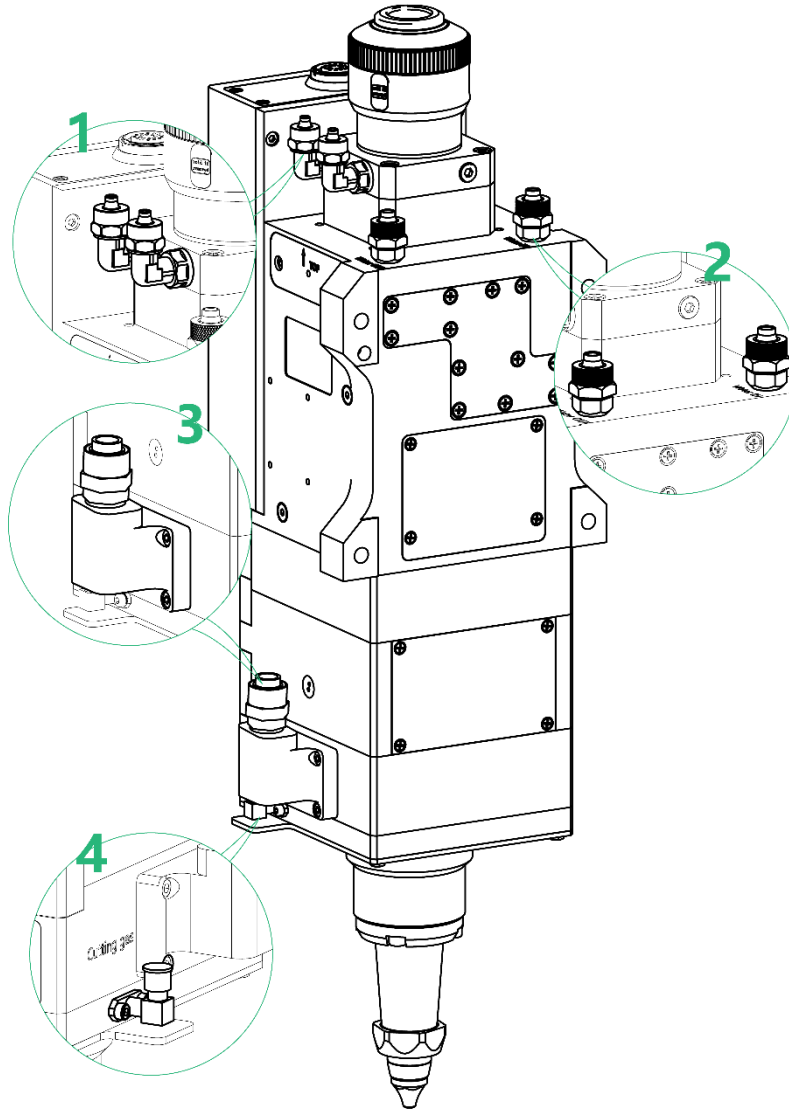

No. 1	Cooling water (ø6)	No. 4	Preamplifier (SMA)
No. 2	Cooling water (ø6)		
No. 3	Cutting gas (ø12)		

2 Mechanical Installation

2.1 Fiber Insertion



WARNING: The optical components must be dust free and all dusts must be cleaned before use. The fiber shall be horizontally inserted into fiber interface to prevent dust from entering the interface and falling on the surface of the lens. Upper limit in the fiber before fixing the laser head.

2.1.1 QBH Fiber Insertion

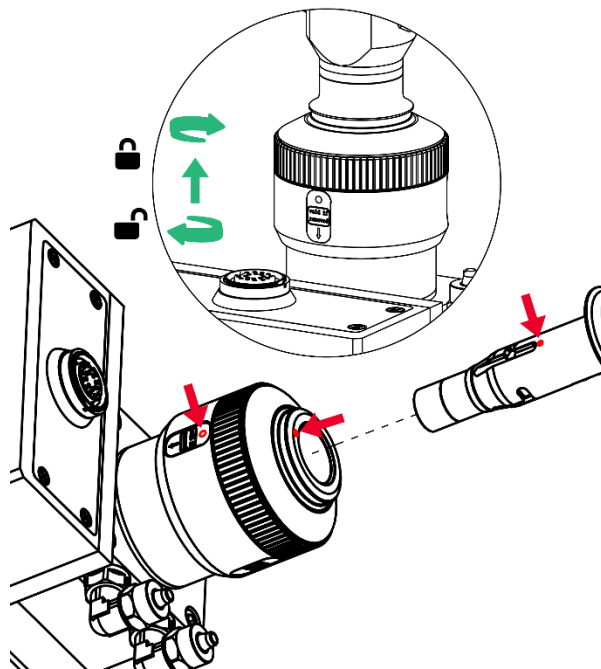

- Align the red point at the end of the QBH interface to the red point of the handwheel.
- Remove QBH dustproof cover.
- Align the red mark of male fiber end to red mark on female QBH of cutting head when you insert the fiber end straightly to bottom of QBH interface of cutting head.
- Turn the QBH handwheel clockwise. It is in place when you hear the "Da" voice, then pull the handwheel up and turn clockwise to end.



It is recommended to use textured tape to seal the connection of female and male fiber interface after the installation is finished in order to prevent from dust as much as possible in critical dusty environment.

2.2 Mounting of Laser Cutting Head

The mounting of laser cutting head to machine tool is shown as below. Customers are advised to Install the laser head perpendicular to the bed surface as requested and make sure the laser head is locked, which is one of the premises to ensure the stable cutting.

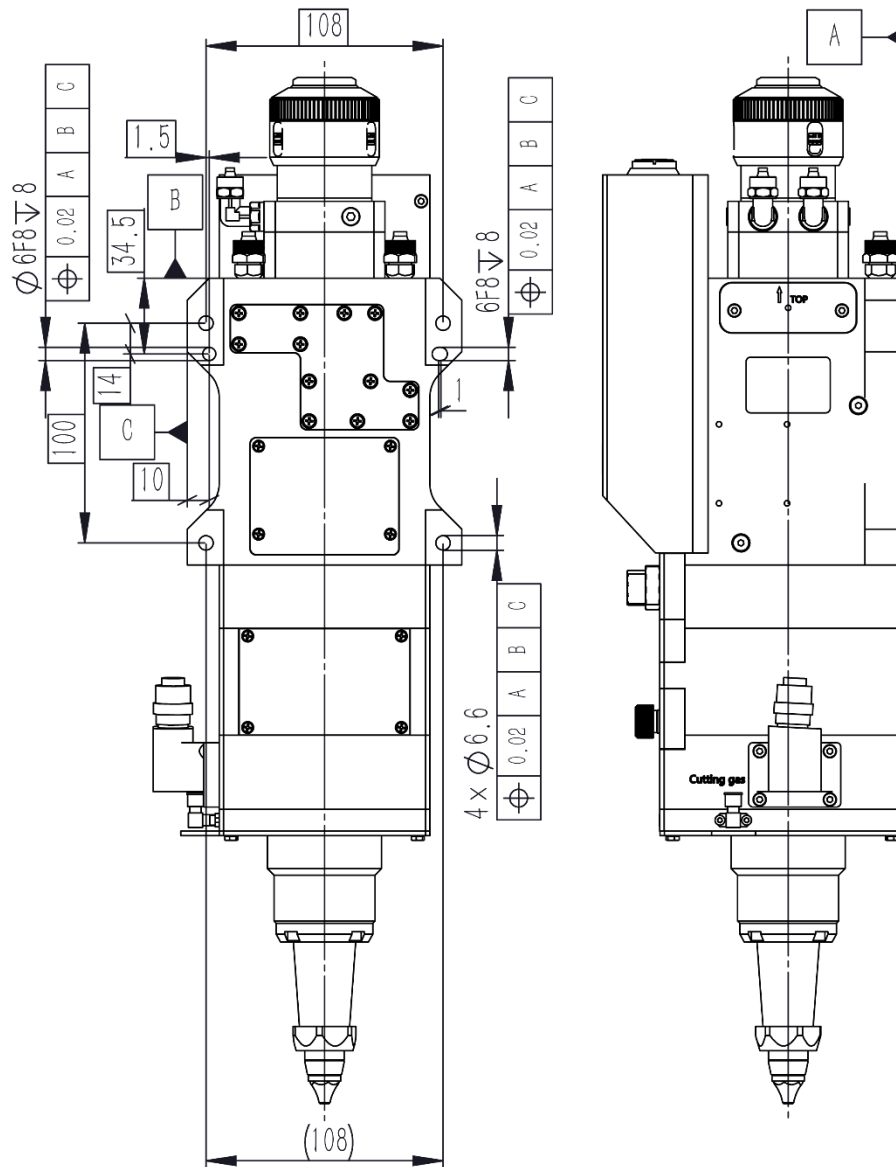

2.3 Earthing of Laser Cutting Head

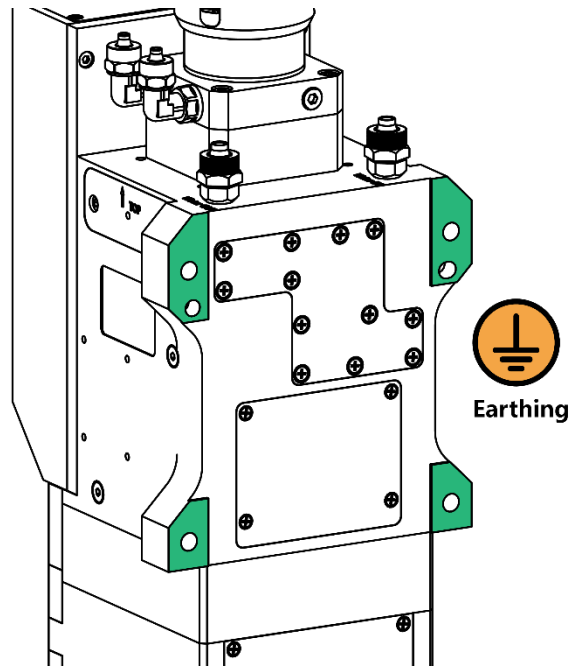

The shaking or vibration of cutting head due to incorrect earthing could cause damage to sensor mechanism and machine.

2.4 Inspection of Top Cover Glass (1st Installation/Replacement of Fiber)

Maintenance or Repair shall be implemented at dust free workstation.

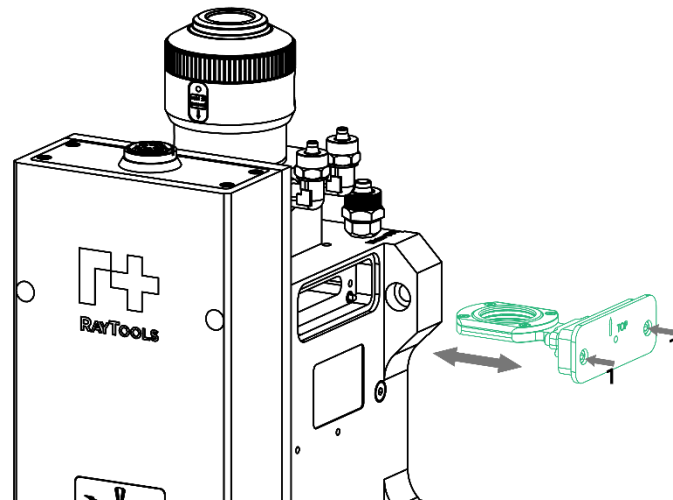

- Loose bolts (item 1) and pull out the glass holder until you see the complete cover glass.
- Seal the openings of cutting head by textured tape immediately.
- Check if the top cover glass is clean. If not, blow the cover glass by clean compressed air until it is clean.



The cover glass shall be replaced if it cannot be cleaned or a damage happens.

2.5 Connection of Cooling Water and Assist Gas

2.5.1 Connection of Cutting Gas

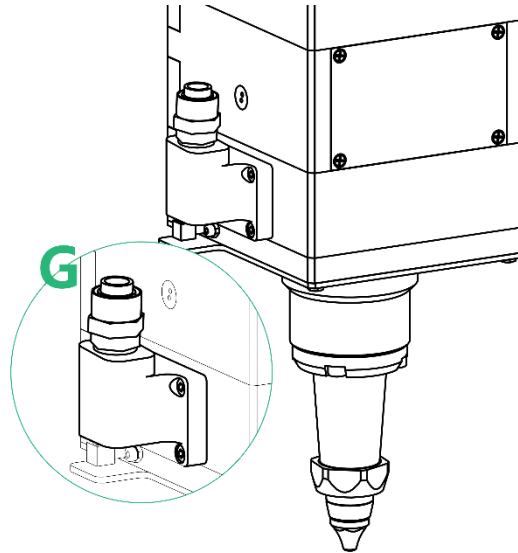

The impurity in cutting gas such as hydrocarbon and steam will damage the lens and cause cutting power fluctuation as well as inconsistencies between the sections of the work piece. The table below is the recommended cutting gas specification. The higher the purity of the gas, the better the quality of the cutting section.

Impurity can be filtered out in gas supply tube, but Oxygen and water vapor can permeate light path through nonmetal materials, which is the source of the appearance of dust and hydrocarbon. Stainless steel fittings are recommended, at the same time must use filters which can remove a minimum of 0.01 micron particle to purify.

A pressure gauge with a stainless steel diaphragm is recommended. Industrial pressure gauges suck in air. Rubber diaphragm produce hydrocarbon by aging or other factors.

Gas	Purity	Maximum content of water vapor	Maximum content of hydrocarbon
Oxygen	99.5%	<5 ppm	<1 ppm
Nitrogen	99.95%	<5 ppm	<1 ppm
Diameter of cutting gas pipe (Outer diameter)		ø12mm (G)	
Gas Pressure		Max. 25bar (2.5MPa)	



CAUTION: Gas interface cannot be replaced arbitrarily especially do not use PTFE TAPE. Otherwise the gas path will be blocked and cannot do normal cutting which will damage cutting head at the same time.



Dried N2 or fine filtered air is recommended for nozzle cooling. The O2 is prohibited for nozzle cooling.

Gas type	N2 or Air (dried and fine filtered)
Gas pressure	Max. 5bar (0.5MPa)
Gas interface	ø12



CAUTION: Gas interface cannot be replaced arbitrarily especially do not use PTFE TAPE. Otherwise the gas path will be blocked and cannot do normal cutting which will damage cutting head at the same time.

2.5.2 Connection of Cooling Water

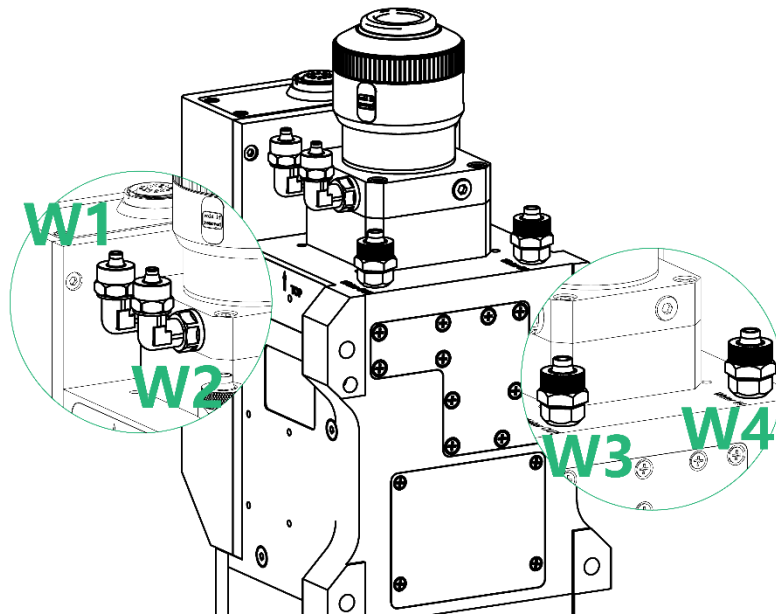

It is important to note that when the laser power is greater than 500W, it is recommended to use water cooling. The recommended water flow is suggested below.

- **Water In: W2**
- **Chain Connection: W1-W3**
- **Water Out: W4**

Outer diameter of water hose	ø6mm
Minimum flow speed	1.5 l/min
Entry pressure	170-520kPa (30-60 psi)
Entry temperature	≥room temperature / > dew point
Hardness (relative to CaCO ₃)	<250mg/liter
PH range	6 to 8
Particle size allowed	Diameter less than 200 microns

2.6 Connection of Cutting Head Cable

Connect the control interface of cutting head by control cable from Raytools as shown below.

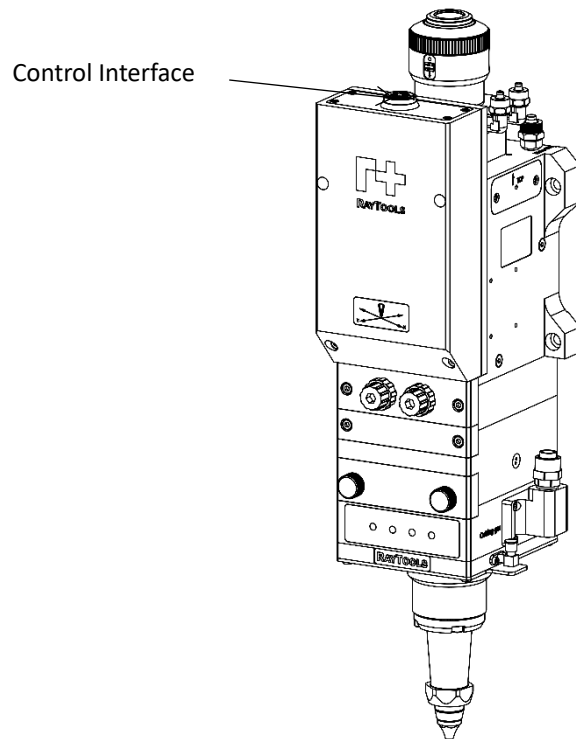

CAUTION: The wiring must be done when the power is off.

3 System Installation and Commissioning

3.1 Auto Focus by 0-10V Analog

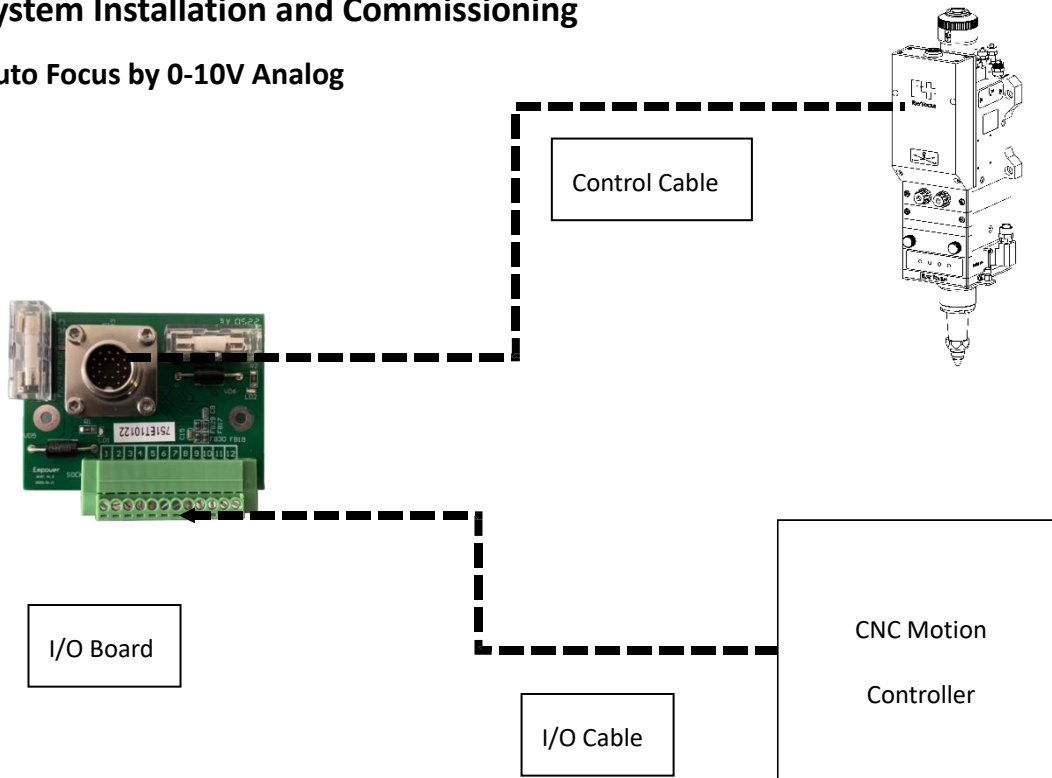

Note: FSCUT motion control system usually gets a 0.3V cutoff voltage and the corresponding voltage range comes to be 0.3V-9.7V.

Optical Configuration (mm)	Mainboard Version	Voltage Range (V)	Focus Range (mm)
CL100/FL220	0-10V Control (Mainboard Ver. 220)	0.3 to 9.7	+40 to -40

Mainboard Version could be identified in mobile APP-BX by last 3 numbers.

XXX0300: Ver.300

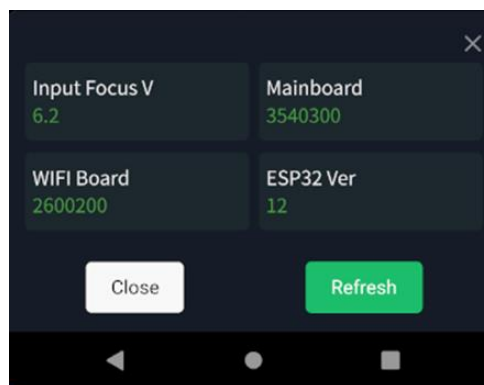

3.1.1 Focus & Voltage Curve

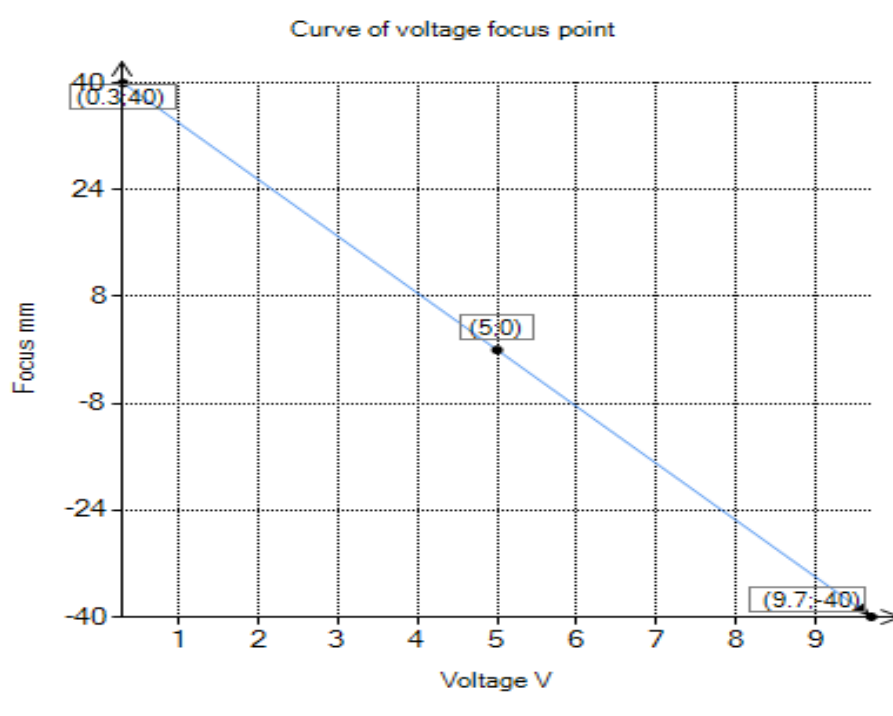

3.1.2 Focus & Voltage Reference Table

Focus (mm)	Voltage (V)	Focus (mm)	Voltage (V)
-40.000	9.700	4.260	4.500
-38.300	9.500	8.510	4.000
-34.040	9.000	12.770	3.500
-29.790	8.500	17.020	3.000
-25.530	8.000	21.280	2.500
-21.280	7.500	25.530	2.000
-17.020	7.000	29.790	1.500
-12.770	6.500	34.040	1.000
-8.5100	6.000	38.300	0.500
-4.2600	5.500	40.000	0.300
0	5.000		

Note:

1. CL100mm/FL220mm with mainboard Ver.220: 0.3V corresponds to +40mm. 9.7V corresponds to -40mm.
2. Mechanical and optical manufacturing tolerance, matching tolerance between imaging proportion of optical component and optical fiber will have other effects on the actual focus position.
3. Adjust the focus offset according to the actual situation.

3.1.3 I/O-CAN Board



Note: Power supply of I/O-CAN is equipped with fuse to safeguard the operation. 2 LED indicators will turn green if the power is feed.

3.1.4 I/O-CAN Definition

Pin No	Item	Definition
1	Power supply 24V	24V to power supply
2	Power supply 0V	0V to power supply
3	I/O 24V	24V to I/O
4	I/O 0V	0V to I/O
5	RS485+	485 communication
6	RS485-	485 communication
7	Input-Home	24V (Uperedge): Manual homing enable (keep PNP while homing) Else: Home disable
8	Input-Focus	24V (Uperedge): Focus enable Else: Focus disable
9	Output-Alarm	Floating (High Impedance State): Alarm; 0V: no alarm
10	Output-Focus reached	0V: Focus reached Floating (High Impedance State): Focus unreached
11	Input-Analog +	0.3V-9.7V Auto focus
12	Input-Analog -	



The connections and settings may differ from one CNC control system to another.

Once the setting is modified, the corresponding wiring method may need to be changed.

3.2 Auto Focus by EtherCAT

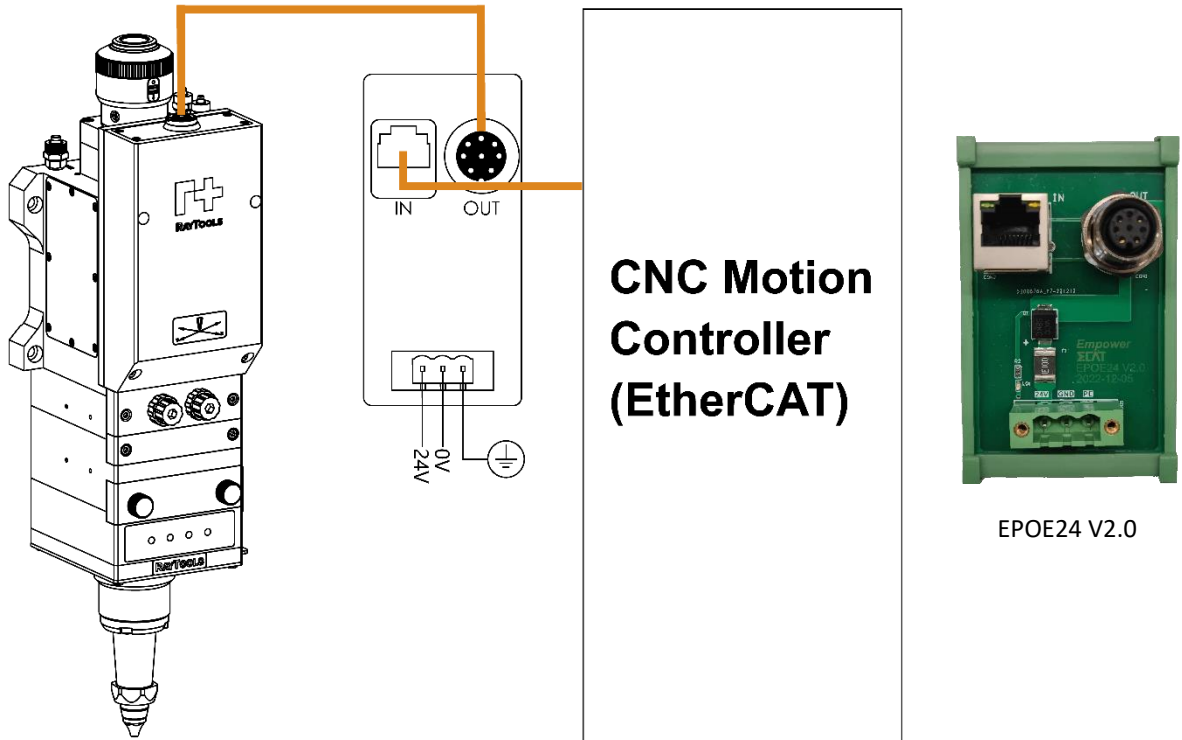

Optical Configuration (mm)	Mainboard Version	Focus Range (mm)
CL100/FL220	EtherCAT Control	+40 to -40

3.3 Mobile APP (APPX-BS)

3.3.1 Download and Installation

- **Apple:** Search “APPX-BS” in App Store to download it accordingly.
- **Android:** please contact Raytools to get the installation pack for APP installation.

3.3.2 WIFI Connection

Connect the WIFI network with laser cutting head and open the app.

- Open WIFI network to connect “BS...” so as to establish the connection with BS08K cutting head.
- Default password: 67601510
- Add device by inputting name “BS08K”, type “BS08K” and URL “192.168.4.1:21880”.

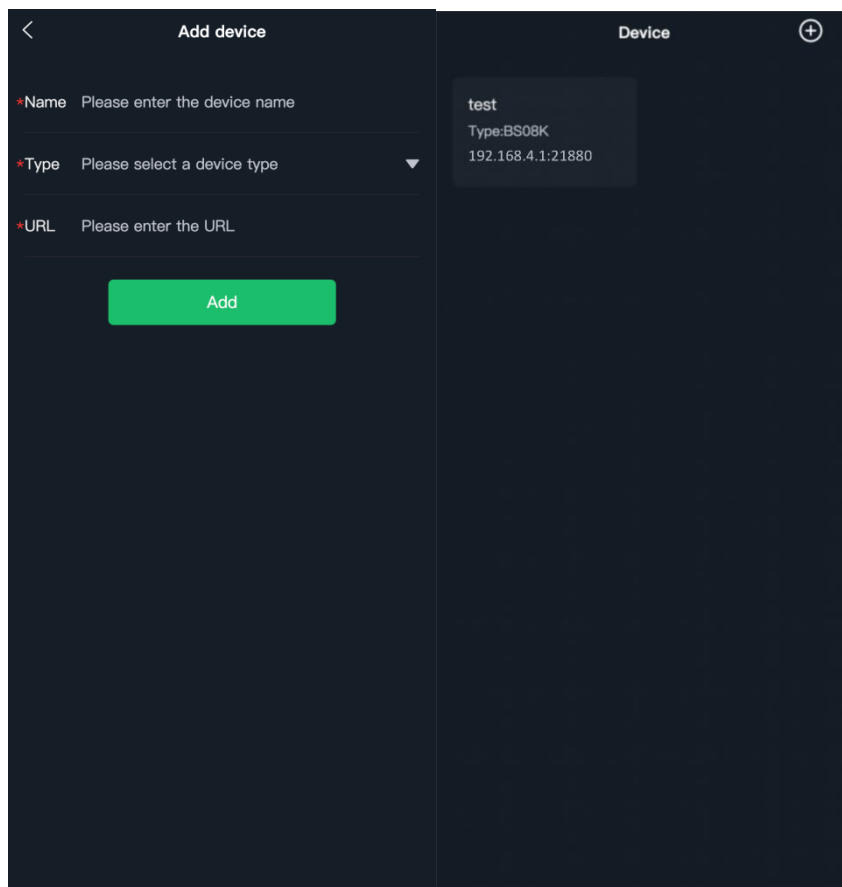

3.3.3 Real-Time Status Monitoring and Data Setting of Cutting Head

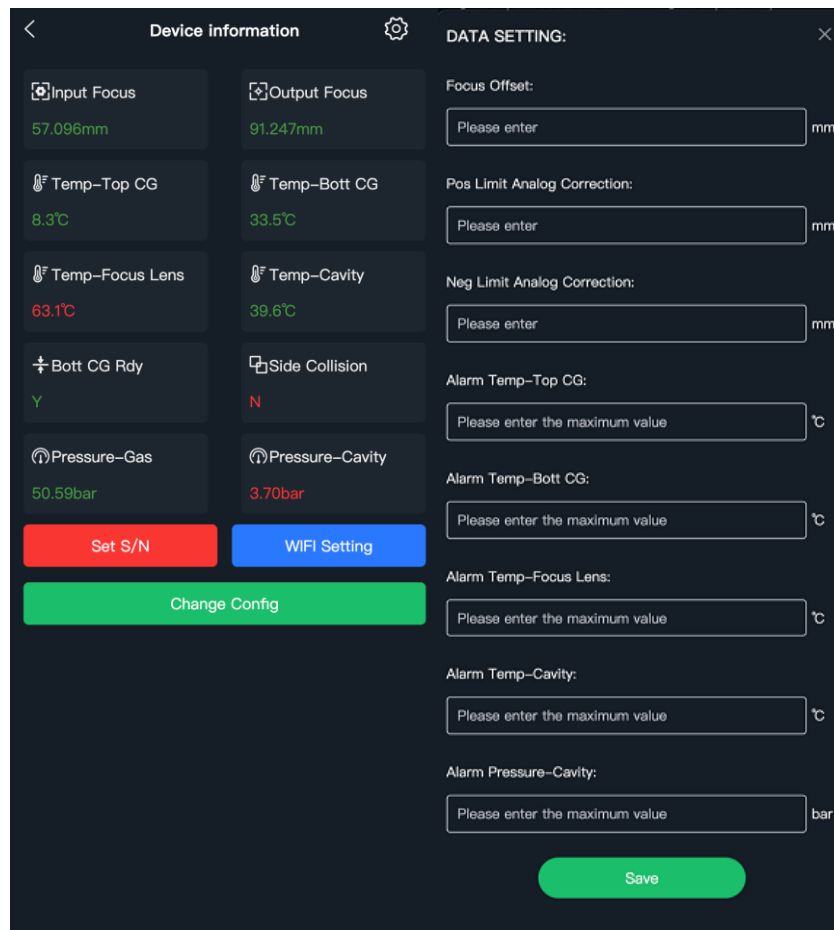

Item	Value
Focus Offset	To correct zero focus according to actual zero focus value
Pos Limit Analog Correction	Preserved
Neg Limit Analog Correction	Preserved
Alarm Temp-Top CG	Alarm value 45 °C
Alarm Temp-Bott CG	Alarm value 45 °C
Alarm Temp- Focus Lens	Alarm value 45 °C
Alarm Temp- Cavity	Alarm value 45 °C
Alarm Pressure-Cavity	Alarm value 1.5 bar

3.3.4 Input Focus Voltage and Other Information

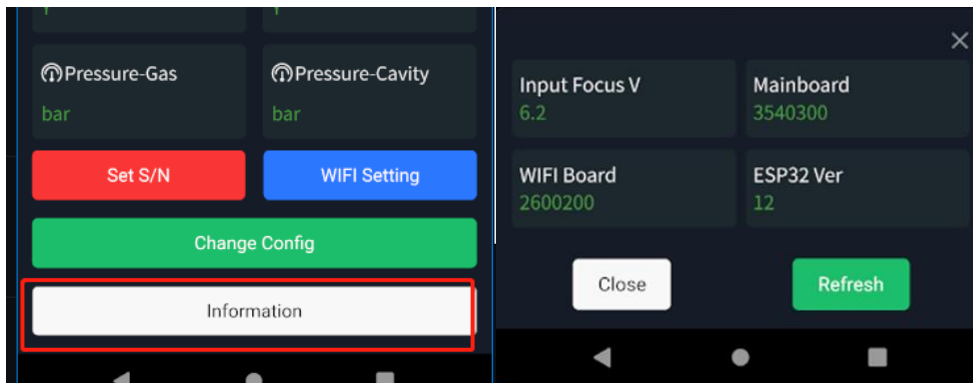

- **Input Focus V:** to show the input focus voltage.
- **Mainboard:** mainboard information of hardware and software.
- **WIFI Board:** WIFI board information of hardware and software.
- **ESP32 Ver:** firmware information.

3.4 PC-based Monitoring Software

3.4.1 Download and Installation

Please contact Raytools to get the installation pack for software installation.

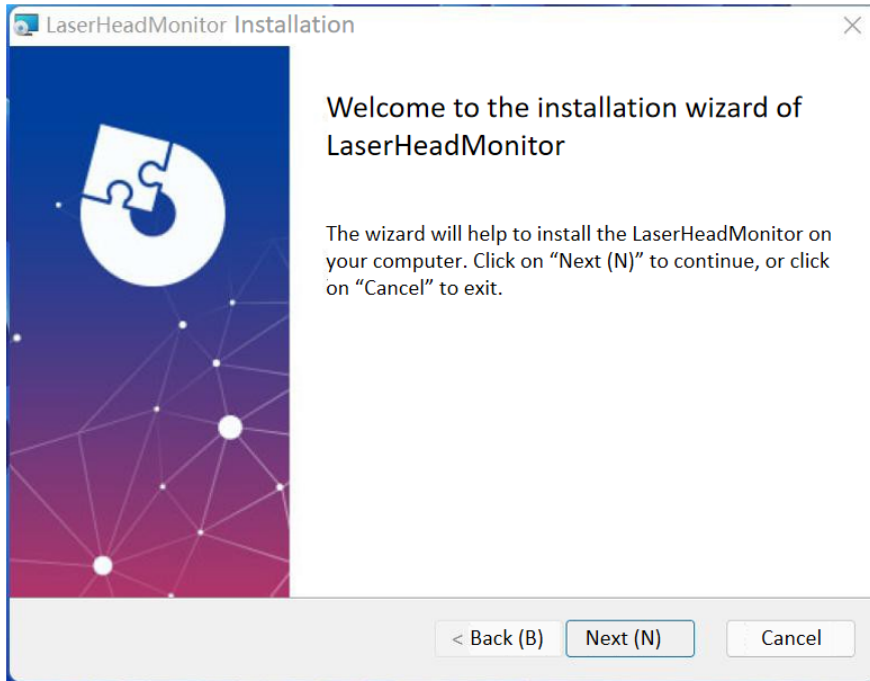

Open the monitoring software and there will be a hover ball on top of the display, double click the hover ball to display detailed information.

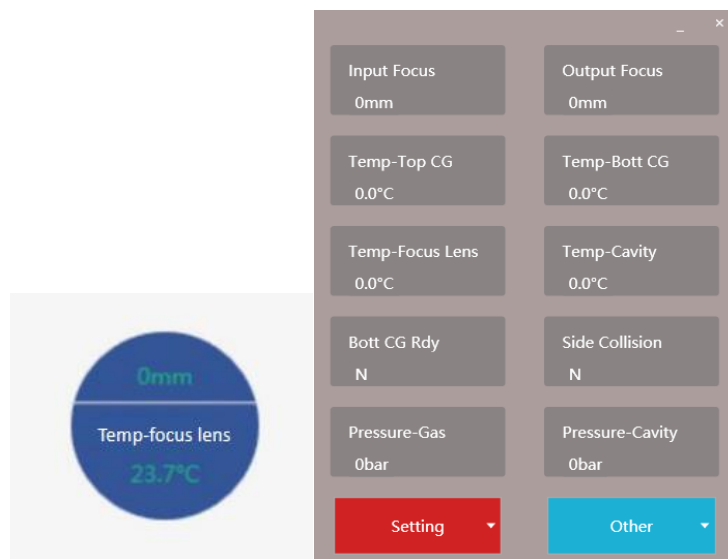

3.4.2 Connection

Connect laser cutting head by WIFI or USB to display real-time data of cutting head. USB connection is recommended to secure more stable connection.

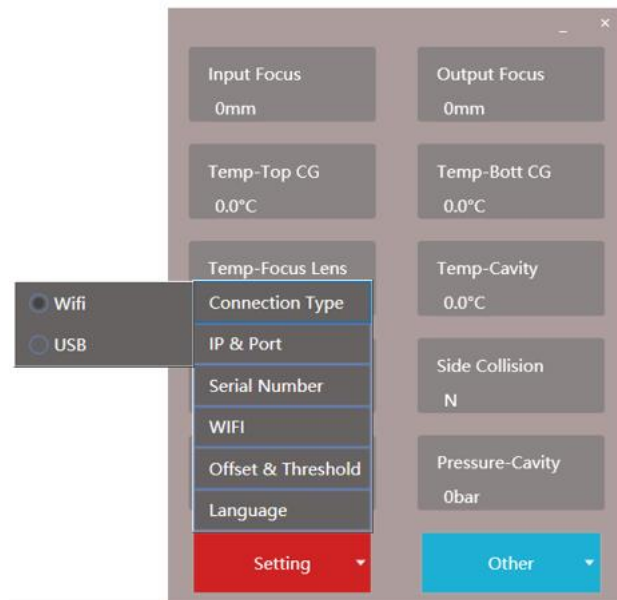

Real-time sensor data can be monitored manually. If an alarm occurs in the cutting head, history data for 1 minute prior to the alarm is auto-recorded.

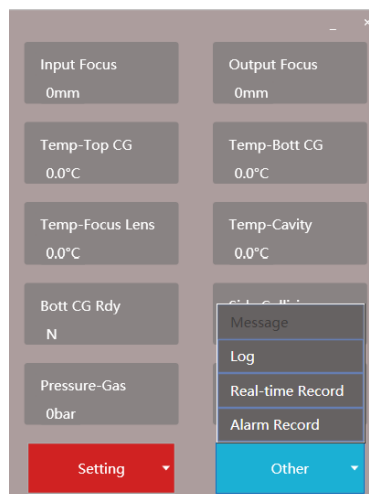

3.4.3 Real-Time Status Monitoring and Data Setting of Cutting Head

Monitoring data and setting could refer to clause 3.3.3

4 Beam Alignment and Zero Focus Correction

4.1 Beam Alignment

Cutting quality in a great extent depends on whether the lens is in the middle. If the lens is not in the middle, the laser beam may contact with nozzle or inner wall to produce high temperature deformation. Lens alignment operation should be considered when nozzle is replaced or the cutting quality declines.

Lens alignment of laser cutting head can be finished by adjusting focus lens, X-Y direction. The X/Y adjusting knob is located above bottom cover glass as shown below. Adjusting the 2 knobs until the beam is located in the middle of nozzle. Make sure the laser beam output from the center of nozzle. A method commonly used is tape dotting method as below:

- Fix the cutting head with a big size nozzle (tip size shall be larger than beam size) or adjust to nearly zero focus.
- Pick a scotch tape, flatten it and stick it to the nozzle tip.
- Open the red light of the laser. Find and observe the position of red light in the scotch tape.
- Shoot laser at low power to check beam penetration size. Beam penetration shall be circle and located in the nozzle tip center.
- Adjust the 2 X/Y adjusting knobs to get beam aligned. The max X/Y adjusting range is roughly from -1.5mm to +1.5mm.
- Tear off the tape and check the shooting hole position in tape.
- Repeat the above steps to find out relatively centered position.

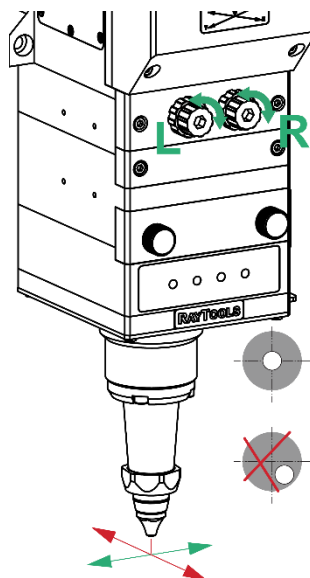

Figure 4.1— Beam Adjustment

4.2 Zero Focus Correction

Laser cutting head is equipped with automated focusing system. But it is required to dot manually to redefine the zero focus position when it is initially set or lenses and lasers are replaced. For details about operating system parameters, please refer to the system instructions. Manual dot can refer to the following steps:

- Attach one textured tape on nozzle tip. Set laser power to 80-100W.
- While moving each 0.5mm focus (as small as possible), shot a hole on the textured tape.
- Dotting several times to find out the focus corresponding to the smallest hole which is supposed to be real zero focus. The zero focus is just at the tip of the nozzle.
- If the real zero focus is not matching the shown focus value, it can be corrected by focus offset function which is set in mobile APP "APPX-BS".

5 Maintenance

5.1 Cleaning Lens

It's necessary to maintain lenses regularly because of the characteristic of laser cutting process. Cleaning to the cover glass once a week is recommended. The collimating lenses and focusing lenses are recommended to be cleaned once every 2~3 months. In order to facilitate the maintenance of the cover glass, the cover glass holder adopts a drawer type structure.

Tools: Dust-proof gloves or fingertip, polyester swab, absolute ethanol, rubber gas blow (purely compressed air).

Cleaning instruction:

- To put fingertip onto left thumb and index finger.
- Spray absolute ethanol onto the polyester swab.
- Hold the edge of the lens with left thumb and index finger gently. (note: avoid touching the surface of the lens by fingertip in case of trace)
- Hold the lens to face eyes by left hand and hold the polyester swab by right hand. Wipe the lens gently in single direction, from bottom to top or from left to right (Should not wipe back and forth in case of secondary pollution to lens) and use rubber blow (purely compressed air) to blow the surface of the lens. Both surfaces should be cleaned. After cleaning, make sure that there is no residual like detergent, floating ash, foreign matters and impurities.

5.2 Removal and Installation of Lenses

The whole process needs to be completed in a dust free room. Wear dust-proof gloves or fingertips when removing or installing the lenses.

5.2.1 Removal and Installation of Bottom Cover Glass/Protection Glass

The cover glass is wearing part which needs to be replaced once it is damaged.

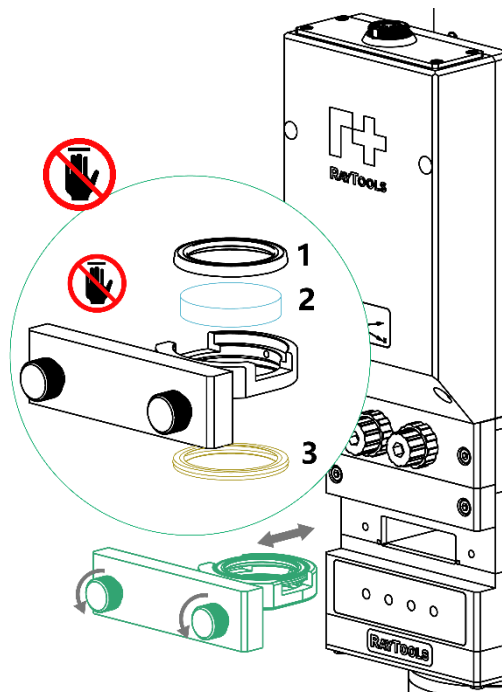

- As shown above, loose the 2 bolts to pull out cover glass holder by pinching 2 edges of drawer type holder.
- Seal the mounting openings by textured tape immediately.
- Remove the pressing ring (1) and cover glass (2) after wearing fingertips
- Clean the cover glass holder and seal ring (3). The elastic seal ring (3) should be replaced if it is damaged.
- Install the cleaned or new cover glass (regardless of the front or back surface) into the holder of cover glass.
- Install the pressing ring.
- Insert the cover glass holder back to the laser head and tighten the bolts.



It is not allowed to pull out the edge of seal ring directly as it is very easy to damage the seal ring. Please wear the clean gloves or fingertips.

5.2.2 Removal and Installation of Middle Cover Glass/Protection Glass

The cover glass is wearing part which needs to be replaced once it is damaged.

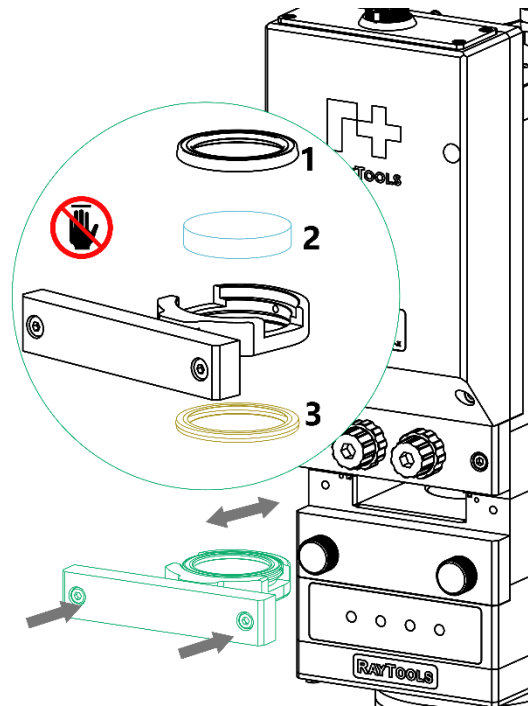

- As shown above, loose the 2 bolts to pull out cover glass holder by pinching 2 edges of drawer type holder.
- Seal the mounting openings by textured tape immediately.
- Remove the pressing ring (1) and cover glass (2) after wearing fingertips
- Clean the cover glass holder and seal ring (3). The elastic seal ring (3) should be replaced if it is damaged.
- Install the cleaned or new cover glass (regardless of the front or back surface) into the holder of cover glass.
- Install the pressing ring.
- Insert the cover glass holder back to the laser head and tighten the bolts.



It is not allowed to pull out the edge of seal ring directly as it is very easy to damage the seal ring. Please wear the clean gloves or fingertips.

5.2.3 Removal and Installation of Focus Lens

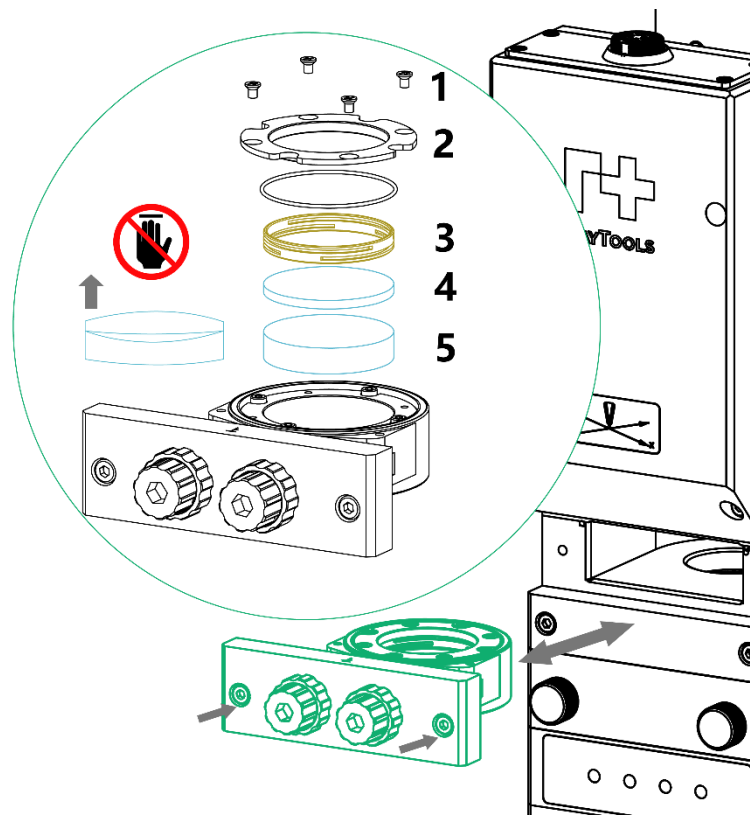

- Clean all dusts on the laser head surface.
- Loosen the 2 bolts as above to pull out focus lens holder.
- Seal the focus lens and mounting openings by textured tape immediately.
- Move the focus lens holder to a dust free room and loosen the bolts (1). Remove the cover (2), pressing ring (3) and focus lenses (4--biconvex one and 5—meniscus one) in sequence.
- Replace or clean the focus lenses (as per direction above, the small curved face of biconvex lens shall be close to concave face of meniscus lens).
- Put focus lenses (5—meniscus one and 4--biconvex one) and pressing ring (3) into the lens holder and cover it by cover (2). Tighten it by bolts (1).
- Insert the focus lens holder into the cutting head and tighten the bolts.



Check if the beam is aligned. If not, please do the alignment as per chapter 4.1.

5.2.4 Removal and Installation of Collimation Lens

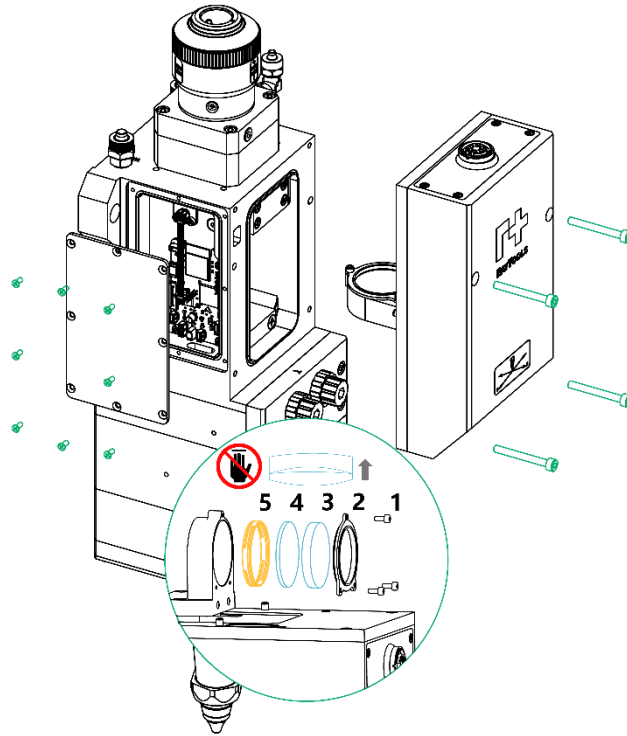

- Remove the laser head and move to a dust free room. Clean all dusts on the laser head surface.
- Loosen the 4 bolts as above to pull out the whole assembly.
- Seal the mounting openings with textured tape immediately.
- Move the assembly to a dust free room and loosen the bolts (1). Remove the cover (2), and collimation lenses (3--meniscus one and 4--biconvex one) in sequence.
- Replace or clean the collimation lenses (as per direction above, the small curved face of the biconvex lens shall be close to the concave face of the meniscus lens).
- Put collimation lenses (4--biconvex one and 3--meniscus one) into the lens holder and cover it with the cover (2). Tighten it with bolts (1).
- Mount the assembly back to the cutting head and tighten the bolts.



Check if the beam is aligned. If not, please do the alignment as per chapter 4.1.

5.3 Replace Ceramic Body and Nozzle

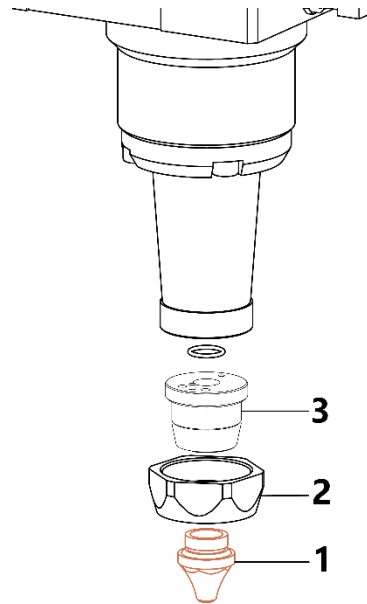

The nozzle is required to be replaced if it gets crash or damaged by laser beam. The dirt on ceramic body is required to be cleaned or to replace the ceramic body if it gets crash.

- Unscrew the nozzle (1).
- Press the ceramic body (3) upward by hand to make it fixed without deflection and then unscrew the retaining ring (2).
- Align the pin hole of the new ceramic body with the locating pin. Press the ceramic body (3) upward by hand and tighten the retaining ring (2).
- Screw the new nozzle (1) and get it properly tightened.
- Do the capacitance calibration once again after replacing the nozzle or ceramic body.



Only tighten the nozzle and retaining ring by hand (without tools) otherwise it could damage the ceramic body.



Keep the contact surface of all parts clean.